



**BEAUMONT-CHERRY VALLEY WATER DISTRICT**

560 Magnolia Avenue, Beaumont, CA 92223

**NOTICE AND AGENDA  
REGULAR MEETING OF THE BOARD OF DIRECTORS  
Wednesday, April 8, 2020 - 6:00 p.m.**

**TELECONFERENCE NOTICE**

*This meeting is hereby noticed pursuant to  
California Government Code Section 54950 et. seq. and  
California Governor's Executive Orders N-29-20 and N-33-20  
The BCVWD Board of Directors will attend via teleconference*

*To access the teleconference:*

*Please dial **712-770-4010** and Enter Code **754421***

*Meeting materials are available on the BCVWD's website:*

<https://bcvwd.org/document-category/regular-board-agendas/>

---

**Call to Order: President Covington**

**Pledge of Allegiance: Director Ramirez**

**Invocation: Director Slawson**

**Announcement of Teleconference Participation**

**Roll Call**

**Teleconference Verification**

**Public Comment**

**PUBLIC COMMENT:**

At this time, any person may address the Board of Directors on matters within its jurisdiction. However, state law prohibits the Board from discussing or taking action on any item not listed on the agenda. Any non-agenda matters that require action will be referred to Staff for a report and possible action at a subsequent meeting. To provide comments on specific agenda items, please complete a speaker's request form and provide the completed form to the Board Secretary prior to the Board meeting. **Please limit your comments to three minutes.** Sharing or passing time to another speaker is not permitted.

**ACTION ITEMS**

*Action may be taken on any item on the agenda. Information on the following items is included in the full Agenda Packet.*

**1. Adjustments to the Agenda**

**2. Consent Calendar:** All matters listed under the Consent Calendar are considered by the Board of Directors to be routine and will be enacted in one motion. There will be no discussion of these items prior to the time the Board considers the motion unless members of the Board, the administrative staff, or the public request specific items to be discussed and/or removed from the Consent Calendar.

- a. February 2020 Budget Variance Report (pages 4 - 9)
- b. February 2020 Cash/Investment Balance Report (page 10)
- c. March 2020 Check Register (pages 11 - 29)
- d. March 2020 Invoices Pending Approval (pages 30 - 31)
- e. Minutes of the Regular Meeting of March 11, 2020 (pages 32 - 38)
- f. Minutes of the Regular Meeting of March 26, 2020 (pages 39 - 48)
- g. Waiver of Second Reading and Adoption of Ordinance 2020-01: Providing for Compensation of the Members of the Board of Directors of the Beaumont-Cherry Valley Water District and Superseding Ordinance 2007-01 (pages 49 - 52)

**3. Consideration of Attendance at the Association of California Water Agencies Annual Spring Summer Conference in Monterey, CA from July 28 – July 31, 2020** (pages 53 – 57)

**4. Noble Creek Recharge Facility Phase I Fencing Project Status Review and Possible Contract Award** (pages 58 - 129)

**5. Budget Amendment Update** (No Staff Report)

**6. Reports For Discussion**

- a. Ad Hoc Committees
- b. General Manager
- c. Directors' Reports
- d. Legal Counsel Report

**7. Announcements**

*All meetings will be held via teleconference until further notice, unless otherwise indicated.*

- Ad Hoc Communications Committee Meeting: Monday, April 13 at 5:30 p.m.
- Engineering Workshop: Thursday, April 23, 2020 at 6:00 p.m.
- Collaborative Agencies Committee Meeting: Wednesday, May 6 at 5:00 p.m. (teleconferencing pending)
- Finance and Audit Committee Meeting: Thursday, May 7, 2020 at 3:00 p.m.
- Regular Board Meeting: Wednesday, May 13, 2020 at 6:00 p.m.
- Personnel Committee Special Meeting: Monday, May 18, 2020 at 5:30 p.m.
- District offices will be closed on Monday, May 25 in observance of Memorial Day
- Beaumont Basin Watermaster Committee: Wednesday, June 3, 2020 at 10 a.m.

**8. Action List for Future Meetings**

- Water supply for BCVWD and the region

**9. Adjournment**

## NOTICES

**AVAILABILITY OF AGENDA MATERIALS** - Agenda exhibits and other writings that are disclosable public records distributed to all or a majority of the members of the Beaumont-Cherry Valley Water District Board of Directors in connection with a matter subject to discussion or consideration at an open meeting of the Board of Directors are available for public inspection in the District's office, at 560 Magnolia Avenue, Beaumont, California ("District Office"). If such writings are distributed to members of the Board less than 72 hours prior to the meeting, they will be available from the District Office at the same time as they are distributed to Board Members, except that if such writings are distributed one hour prior to, or during the meeting, they can be made available from the District Office in the Board Room of the District's Office. Materials may also be available on the District's website: [www.bcvwd.org](http://www.bcvwd.org).

**REVISIONS TO THE AGENDA** - In accordance with §54954.2(a) of the Government Code (Brown Act), revisions to this Agenda may be made up to 72 hours before the Board Meeting, if necessary, after mailings are completed. Interested persons wishing to receive a copy of the set Agenda may pick one up at the District's Main Office, located at 560 Magnolia Avenue, Beaumont, California, up to 72 hours prior to the Board Meeting.

**REQUIREMENTS RE: DISABLED ACCESS** - In accordance with §54954.2(a), requests for a disability related modification or accommodation, including auxiliary aids or services, in order to attend or participate in a meeting, should be made to the District Office, at least 48 hours in advance of the meeting to ensure availability of the requested service or accommodation. The District Office may be contacted by telephone at (951) 845-9581, email at [info@bcvwd.org](mailto:info@bcvwd.org) or in writing to the Beaumont-Cherry Valley Water District, 560 Magnolia Avenue, Beaumont, California 92223.

## CERTIFICATION OF POSTING

I certify that on or before April 5, 2020, a copy of the foregoing notice was posted near the regular meeting place of the Board of Directors of Beaumont-Cherry Valley Water District and to its website at least 72 hours in advance of the meeting (Government Code §54954.2(a)).



Digitally signed by Yolanda Rodriguez  
DN: cn=Yolanda Rodriguez, o=Finance and  
Administration, ou=Finance and Administration,  
email=yolanda.rodriguez@bcvwd.org, c=US  
Date: 2020.04.02 17:32:29 -0700

---

Yolanda Rodriguez  
Director of Finance and Administration

General Ledger  
Budget Variance Revenue

User: wclayton  
Printed: 3/26/2020 5:24:19 PM  
Period 02 - 02  
Fiscal Year 2020

Beaumont-Cherry Valley Water District

560 Magnolia Avenue  
Beaumont CA 92223  
(951) 845-9581  
www.bcvwd.org



Account Number	Description	Budget	Period Amt	End Bal	Variance	% Avail/ Uncollect
<b>50</b>	<b>GENERAL</b>					
01-50-510-490001	Interest Income - Bonita Vista	\$ 1,600.00	\$ 231.29	\$ 265.48	\$ 1,334.52	83.41%
01-50-510-490011	Interest Income-Fairway Canyon	\$ 46,829.00	\$ -	\$ -	\$ 46,829.00	100.00%
01-50-510-490021	Interest Income - General	\$ 800,000.00	\$ 50,782.13	\$ 108,847.67	\$ 691,152.33	86.39%
	<b>Interest Income</b>	<b>\$ 848,429.00</b>	<b>\$ 51,013.42</b>	<b>\$ 109,113.15</b>	<b>\$ 739,315.85</b>	<b>87.14%</b>
01-50-510-481001	Fac Fees-Wells	\$ 580,800.00	\$ 1,936.00	\$ 3,872.00	\$ 576,928.00	99.33%
01-50-510-481006	Fac Fees-Water Rights (SWP)	\$ 367,500.00	\$ 1,225.00	\$ 2,450.00	\$ 365,050.00	99.33%
01-50-510-481012	Fac Fees-Water Treatment Plant	\$ 276,300.00	\$ 921.00	\$ 1,842.00	\$ 274,458.00	99.33%
01-50-510-481018	Fac Fees-Local Water Resources	\$ 145,500.00	\$ 485.00	\$ 970.00	\$ 144,530.00	99.33%
01-50-510-481024	Fac Fees-Recycld Wtr Facilities	\$ 420,600.00	\$ 7,935.32	\$ 9,337.32	\$ 411,262.68	97.78%
01-50-510-481030	Fac Fees-Transmission (16")	\$ 470,400.00	\$ 1,568.00	\$ 3,136.00	\$ 467,264.00	99.33%
01-50-510-481036	Fac Fees-Storage	\$ 602,400.00	\$ 2,008.00	\$ 4,016.00	\$ 598,384.00	99.33%
01-50-510-481042	Fac Fees-Booster	\$ 41,700.00	\$ 139.00	\$ 278.00	\$ 41,422.00	99.33%
01-50-510-481048	Fac Fees-Pressure Reducng Stns	\$ 21,300.00	\$ 71.00	\$ 142.00	\$ 21,158.00	99.33%
01-50-510-481054	Fac Fees-Misc Projects	\$ 18,600.00	\$ 62.00	\$ 124.00	\$ 18,476.00	99.33%
01-50-510-481060	Fac Fees-Financing Costs	\$ 91,500.00	\$ 501.85	\$ 806.85	\$ 90,693.15	99.12%
01-50-510-485001	Front Footage Fees	\$ -	\$ 2,194.50	\$ 6,441.00	\$ (6,441.00)	0.00%
	<b>Non-Operating Revenue</b>	<b>\$ 3,036,600.00</b>	<b>\$ 19,046.67</b>	<b>\$ 33,415.17</b>	<b>\$ 3,003,184.83</b>	<b>98.90%</b>
01-50-510-410100	Sales	\$ 5,042,921.00	\$ 273,182.84	\$ 530,647.49	\$ 4,512,273.51	89.48%
01-50-510-410151	Agricultural Irrigation Sales	\$ 20,000.00	\$ (148.47)	\$ 1,210.99	\$ 18,789.01	93.95%
01-50-510-410171	Construction Sales	\$ 90,801.00	\$ (34,981.85)	\$ (13,813.80)	\$ 104,614.80	115.21%
01-50-510-413001	Backflow Admin Charges	\$ 44,000.00	\$ 5,273.44	\$ 7,980.74	\$ 36,019.26	81.86%
01-50-510-413011	Fixed Meter Charges	\$ 3,281,794.00	\$ 312,544.09	\$ 581,290.56	\$ 2,700,503.44	82.29%
01-50-510-413021	Meter Fees	\$ 325,000.00	\$ 39,017.00	\$ 105,996.00	\$ 219,004.00	67.39%
01-50-510-415001	SGPWA Importation Charges	\$ 2,298,354.00	\$ 112,219.76	\$ 241,627.88	\$ 2,056,726.12	89.49%
01-50-510-415011	SCE Power Charges	\$ 1,635,854.00	\$ 80,505.48	\$ 173,341.74	\$ 1,462,512.26	89.40%
01-50-510-417001	2nd Notice Penalties	\$ 100,665.00	\$ 6,030.00	\$ 17,985.00	\$ 82,680.00	82.13%
01-50-510-417011	3rd Notice Charges	\$ 35,000.00	\$ 3,950.00	\$ 7,825.00	\$ 27,175.00	77.64%
01-50-510-417021	Account Reinstatement Fees	\$ 44,000.00	\$ 50.00	\$ 3,550.00	\$ 40,450.00	91.93%
01-50-510-417031	Lien Processing Fees	\$ 4,000.00	\$ 100.00	\$ 900.00	\$ 3,100.00	77.50%
01-50-510-417041	Credit Check Processing Fees	\$ 10,000.00	\$ 860.00	\$ 1,495.00	\$ 8,505.00	85.05%
01-50-510-417051	Returned Check Fees	\$ 3,000.00	\$ 375.00	\$ 750.00	\$ 2,250.00	75.00%
01-50-510-417061	Custmr Damages/Upgrade Charges	\$ 22,000.00	\$ 9,736.00	\$ 11,866.83	\$ 10,133.17	46.06%
01-50-510-417071	After Hours Call Out Charges	\$ 650.00	\$ -	\$ -	\$ 650.00	100.00%
01-50-510-417081	Bench Test Fees	\$ 90.00	\$ 30.00	\$ 30.00	\$ 60.00	66.67%
01-50-510-417091	Credit Card Processing Fees	\$ 45,000.00	\$ 4,252.16	\$ 9,209.24	\$ 35,790.76	79.54%
01-50-510-419011	Development Income	\$ 60,000.00	\$ 11,286.59	\$ 21,833.91	\$ 38,166.09	63.61%
01-50-510-419031	Well Maintenance Reimbursemt	\$ 7,500.00	\$ -	\$ -	\$ 7,500.00	100.00%
01-50-510-419061	Miscellaneous Income	\$ 100.00	\$ 3,987.60	\$ 3,987.60	\$ (3,887.60)	-3887.60%
	<b>Operating Revenue</b>	<b>\$ 13,070,729.00</b>	<b>\$ 828,269.64</b>	<b>\$ 1,707,714.18</b>	<b>\$ 11,363,014.82</b>	<b>86.93%</b>
01-50-510-471001	Rent - 12303 Oak Glen	\$ 2,400.00	\$ 200.00	\$ 400.00	\$ 2,000.00	83.33%
01-50-510-471011	Rent - 13695 Oak Glen	\$ 2,400.00	\$ 200.00	\$ 400.00	\$ 2,000.00	83.33%
01-50-510-471021	Rent - 13697 Oak Glen	\$ 2,400.00	\$ 200.00	\$ 400.00	\$ 2,000.00	83.33%
01-50-510-471031	Rent - 9781 Avenida Miravilla	\$ 2,400.00	\$ 200.00	\$ 400.00	\$ 2,000.00	83.33%
01-50-510-471101	Util - 12303 Oak Glen	\$ 2,688.00	\$ 316.39	\$ 666.16	\$ 2,021.84	75.22%
01-50-510-471111	Util - 13695 Oak Glen	\$ 2,158.00	\$ 322.28	\$ 424.32	\$ 1,733.68	80.34%
01-50-510-471121	Util - 13697 Oak Glen	\$ 3,631.00	\$ 620.49	\$ 794.84	\$ 2,836.16	78.11%
01-50-510-471131	Util - 9781 Avenida Miravilla	\$ 1,948.00	\$ 407.54	\$ 1,454.83	\$ 1,454.83	74.68%
	<b>Rent/Utilities</b>	<b>\$ 20,025.00</b>	<b>\$ 2,466.70</b>	<b>\$ 3,978.49</b>	<b>\$ 16,046.51</b>	<b>80.13%</b>
01-50-510-302011	Reserve Contribution	\$ 394,012.00	\$ -	\$ -	\$ -	100.00%
<b>Revenue Total</b>		<b>\$ 17,369,795.00</b>	<b>\$ 900,796.43</b>	<b>\$ 1,854,220.99</b>	<b>\$ 15,121,562.01</b>	<b>87.06%</b>

General Ledger

Budget Variance Expense

User: wclayton  
 Printed: 3/26/2020 2:03:32 PM  
 Period 02 - 02  
 Fiscal Year 2020

Beaumont-Cherry Valley Water District

560 Magnolia Avenue  
 Beaumont CA 92223  
 (951) 845-9581  
 www.bcvwd.org



Account Number	Description	Budget	Period Amt	End Bal	Variance	Encumbered	% Avail/ Uncollect
<b>10</b>	<b>BOARD OF DIRECTORS</b>						
01-10-110-500101	Board of Directors Fees	\$ 53,600.00	\$ 4,000.00	\$ 5,400.00	\$ 48,200.00	\$ -	89.93%
01-10-110-500115	Social Security	\$ 3,324.00	\$ 248.00	\$ 334.80	\$ 2,989.20	\$ -	89.93%
01-10-110-500120	Medicare	\$ 779.00	\$ 58.00	\$ 78.30	\$ 700.70	\$ -	89.95%
01-10-110-500145	Workers' Compensation	\$ 776.00	\$ 22.62	\$ 30.54	\$ 745.46	\$ -	96.06%
01-10-110-500175	Training/Education/Mtgs/Travel	\$ 10,300.00	\$ -	\$ -	\$ 10,300.00	\$ -	100.00%
	<b>Board of Directors Personnel</b>	<b>\$ 68,779.00</b>	<b>\$ 4,328.62</b>	<b>\$ 5,843.64</b>	<b>\$ 62,935.36</b>	<b>\$ -</b>	<b>91.50%</b>
01-10-110-550042	Supplies-Other	\$ 1,030.00	\$ -	\$ -	\$ 1,030.00	\$ -	100.00%
	<b>Board of Directors Materials &amp; Supplies</b>	<b>\$ 1,030.00</b>	<b>\$ -</b>	<b>\$ -</b>	<b>\$ 1,030.00</b>	<b>\$ -</b>	<b>100.00%</b>
01-10-110-550012	Election Expenses	\$ 10,000.00	\$ -	\$ -	\$ 10,000.00	\$ -	100.00%
01-10-110-550051	Advertising/Legal Notices	\$ 100.00	\$ -	\$ -	\$ 100.00	\$ -	100.00%
	<b>Board of Directors Services</b>	<b>\$ 10,100.00</b>	<b>\$ -</b>	<b>\$ -</b>	<b>\$ 10,100.00</b>	<b>\$ -</b>	<b>100.00%</b>
<b>Expense Total</b>	<b>BOARD OF DIRECTORS</b>	<b>\$ 79,909.00</b>	<b>\$ 4,328.62</b>	<b>\$ 5,843.64</b>	<b>\$ 74,065.36</b>	<b>\$ -</b>	<b>92.69%</b>
<b>20</b>	<b>ENGINEERING</b>						
01-20-210-500105	Labor	\$ 568,262.00	\$ 21,003.36	\$ 38,714.96	\$ 529,547.04	\$ -	93.19%
01-20-210-500115	Social Security	\$ 39,710.00	\$ 1,945.70	\$ 3,065.04	\$ 36,644.96	\$ -	92.28%
01-20-210-500120	Medicare	\$ 9,294.00	\$ 342.76	\$ 604.54	\$ 8,689.46	\$ -	93.50%
01-20-210-500125	Health Insurance	\$ 104,544.00	\$ 3,888.03	\$ 7,776.06	\$ 96,767.94	\$ -	92.56%
01-20-210-500140	Life Insurance	\$ 2,784.00	\$ 80.94	\$ 154.08	\$ 2,629.92	\$ -	94.47%
01-20-210-500143	EAP Program	\$ 288.00	\$ 5.14	\$ 10.27	\$ 277.73	\$ -	96.43%
01-20-210-500145	Workers' Compensation	\$ 8,489.00	\$ 161.85	\$ 285.47	\$ 8,203.53	\$ -	96.64%
01-20-210-500150	Unemployment Insurance	\$ 19,324.00	\$ -	\$ -	\$ 19,324.00	\$ -	100.00%
01-20-210-500155	Retirement/CalPERS	\$ 93,299.00	\$ 2,918.79	\$ 5,233.56	\$ 88,065.44	\$ -	94.39%
01-20-210-500165	Uniforms & Employee Benefits	\$ 350.00	\$ -	\$ -	\$ 350.00	\$ -	100.00%
01-20-210-500175	Training/Education/Mtgs/Travel	\$ 6,000.00	\$ -	\$ 60.00	\$ 5,940.00	\$ -	99.00%
01-20-210-500180	Accrued Sick Leave Expense	\$ 28,287.00	\$ 336.50	\$ 673.00	\$ 27,614.00	\$ -	97.62%
01-20-210-500185	Accrued Vacation Leave Expense	\$ 20,202.00	\$ -	\$ -	\$ 20,202.00	\$ -	100.00%
01-20-210-500187	Accrual Leave Payments	\$ 14,745.00	\$ -	\$ -	\$ 14,745.00	\$ -	100.00%
01-20-210-500195	CIP Related Labor	\$ (225,000.00)	\$ (9,681.55)	\$ (11,535.66)	\$ (213,464.34)	\$ -	94.87%
	<b>Engineering Personnel</b>	<b>\$ 690,578.00</b>	<b>\$ 21,001.52</b>	<b>\$ 45,041.32</b>	<b>\$ 645,536.68</b>	<b>\$ -</b>	<b>93.48%</b>
01-20-210-540048	Permits, Fees & Licensing	\$ 2,060.00	\$ -	\$ -	\$ 2,060.00	\$ -	100.00%
	<b>Engineering Materials &amp; Supplies</b>	<b>\$ 2,060.00</b>	<b>\$ -</b>	<b>\$ -</b>	<b>\$ 2,060.00</b>	<b>\$ -</b>	<b>100.00%</b>
01-20-210-550030	Membership Dues	\$ 800.00	\$ -	\$ 300.00	\$ 500.00	\$ -	62.50%
01-20-210-550051	Advertising/Legal Notices	\$ 2,000.00	\$ -	\$ -	\$ 2,000.00	\$ -	100.00%
01-20-210-580031	Outside Engineering	\$ 61,800.00	\$ -	\$ -	\$ 61,800.00	\$ -	100.00%
01-20-210-580032	CIP Related Outside Engineering	\$ (41,280.00)	\$ -	\$ -	\$ (41,280.00)	\$ -	100.00%
	<b>Engineering Services</b>	<b>\$ 23,320.00</b>	<b>\$ -</b>	<b>\$ 300.00</b>	<b>\$ 23,020.00</b>	<b>\$ -</b>	<b>98.71%</b>
<b>Expense Total</b>	<b>ENGINEERING</b>	<b>\$ 715,958.00</b>	<b>\$ 21,001.52</b>	<b>\$ 45,341.32</b>	<b>\$ 670,616.68</b>	<b>\$ -</b>	<b>93.67%</b>
<b>30</b>	<b>FINANCE &amp; ADMIN SERVICES</b>						
01-30-310-500105	Labor	\$ 1,141,273.00	\$ 72,269.15	\$ 114,366.13	\$ 1,026,906.87	\$ -	89.98%
01-30-310-500110	Overtime	\$ 1,185.00	\$ 225.75	\$ 225.75	\$ 959.25	\$ -	80.95%
01-30-310-500115	Social Security	\$ 87,852.00	\$ 6,335.72	\$ 9,284.28	\$ 78,567.72	\$ -	89.43%
01-30-310-500120	Medicare	\$ 20,557.00	\$ 1,485.03	\$ 2,174.62	\$ 18,382.38	\$ -	89.42%
01-30-310-500125	Health Insurance	\$ 287,496.00	\$ 15,692.27	\$ 31,384.54	\$ 256,111.46	\$ -	89.08%
01-30-310-500130	CalPERS Health Admin Costs	\$ 3,000.00	\$ 158.21	\$ 327.62	\$ 2,672.38	\$ -	89.08%
01-30-310-500140	Life Insurance	\$ 6,876.00	\$ 334.09	\$ 657.52	\$ 6,218.48	\$ -	90.44%
01-30-310-500143	EAP Program	\$ 860.00	\$ 28.27	\$ 56.54	\$ 803.46	\$ -	93.43%
01-30-310-500145	Workers' Compensation	\$ 16,632.00	\$ 441.12	\$ 715.43	\$ 15,916.57	\$ -	95.70%
01-30-310-500150	Unemployment Insurance	\$ 38,808.00	\$ -	\$ -	\$ 38,808.00	\$ -	100.00%
01-30-310-500155	Retirement/CalPERS	\$ 213,002.00	\$ 18,243.45	\$ 28,027.91	\$ 184,974.09	\$ -	86.84%
01-30-310-500161	Estim Current Yr OPEB Expense	\$ 107,150.00	\$ -	\$ -	\$ 107,150.00	\$ -	100.00%
01-30-310-500165	Uniforms & Employee Benefits	\$ 1,000.00	\$ -	\$ 23.71	\$ 976.29	\$ -	97.63%
01-30-310-500175	Training/Education/Mtgs/Travel	\$ 25,000.00	\$ 1,941.50	\$ 8,501.58	\$ 16,498.42	\$ -	65.99%

Account Number	Description	Budget	Period Amt	End Bal	Variance	Encumbered	% Avail/ Uncollect
01-30-310-500180	Accrued Sick Leave Expense	\$ 58,662.00	\$ 924.40	\$ 3,237.38	\$ 55,424.62	\$ -	94.48%
01-30-310-500185	Accrued Vacation Leave Expense	\$ 90,288.00	\$ 1,040.14	\$ 2,878.67	\$ 87,409.33	\$ -	96.81%
01-30-310-500187	Accrual Leave Payments	\$ 115,720.00	\$ 27,657.64	\$ 28,810.64	\$ 86,909.36	\$ -	75.10%
01-30-310-550024	Employment Testing	\$ 206.00	\$ -	\$ -	\$ 206.00	\$ -	100.00%
01-30-315-500105	Labor	\$ 140,662.00	\$ 9,718.40	\$ 15,792.40	\$ 124,869.60	\$ -	88.77%
01-30-315-500115	Social Security	\$ 12,380.00	\$ 602.98	\$ 2,561.73	\$ 9,818.27	\$ -	79.31%
01-30-315-500120	Medicare	\$ 2,896.00	\$ 141.02	\$ 599.12	\$ 2,296.88	\$ -	79.31%
01-30-315-500125	Health Insurance	\$ 26,136.00	\$ 2,114.24	\$ 4,228.48	\$ 21,907.52	\$ -	83.82%
01-30-315-500140	Life Insurance	\$ 912.00	\$ 46.16	\$ 90.18	\$ 821.82	\$ -	90.11%
01-30-315-500143	EAP Program	\$ 72.00	\$ 2.57	\$ 5.14	\$ 66.86	\$ -	92.86%
01-30-315-500145	Workers' Compensation	\$ 2,032.00	\$ 55.00	\$ 89.38	\$ 1,942.62	\$ -	95.60%
01-30-315-500150	Unemployment Insurance	\$ 4,783.00	\$ -	\$ -	\$ 4,783.00	\$ -	100.00%
01-30-315-500155	Retirement/CalPERS	\$ 15,604.00	\$ 1,027.63	\$ 1,780.91	\$ 13,823.09	\$ -	88.59%
01-30-315-500175	Training/Education/Mtgs/Travel	\$ 4,120.00	\$ -	\$ -	\$ 4,120.00	\$ -	100.00%
01-30-315-500180	Accrued Sick Leave Expense	\$ 8,029.00	\$ -	\$ -	\$ 8,029.00	\$ -	100.00%
01-30-315-500185	Accrued Vacation Leave Expense	\$ 14,597.00	\$ -	\$ -	\$ 14,597.00	\$ -	100.00%
01-30-315-500187	Accrual Leave Payments	\$ 35,678.00	\$ -	\$ 25,510.80	\$ 10,167.20	\$ -	28.50%
01-30-315-500195	CIP Related Labor	\$ (32,875.00)	\$ -	\$ -	\$ (32,875.00)	\$ -	100.00%
01-30-320-500105	Labor	\$ 66,992.00	\$ 4,160.00	\$ 6,500.00	\$ 60,492.00	\$ -	90.30%
01-30-320-500110	Overtime	\$ 569.00	\$ -	\$ -	\$ 569.00	\$ -	100.00%
01-30-320-500115	Social Security	\$ 4,590.00	\$ 257.94	\$ 419.15	\$ 4,170.85	\$ -	90.87%
01-30-320-500120	Medicare	\$ 1,075.00	\$ 60.32	\$ 98.02	\$ 976.98	\$ -	90.88%
01-30-320-500125	Health Insurance	\$ 26,136.00	\$ 1,239.86	\$ 2,479.72	\$ 23,656.28	\$ -	90.51%
01-30-320-500140	Life Insurance	\$ 444.00	\$ 20.24	\$ 39.06	\$ 404.94	\$ -	91.20%
01-30-320-500143	EAP Program	\$ 72.00	\$ 2.57	\$ 5.14	\$ 66.86	\$ -	92.86%
01-30-320-500145	Workers' Compensation	\$ 968.00	\$ 23.54	\$ 38.25	\$ 929.75	\$ -	96.05%
01-30-320-500150	Unemployment Insurance	\$ 2,278.00	\$ -	\$ -	\$ 2,278.00	\$ -	100.00%
01-30-320-500155	Retirement/CalPERS	\$ 11,866.00	\$ 313.16	\$ 508.89	\$ 11,357.11	\$ -	95.71%
01-30-320-500165	Uniforms & Employee Benefits	\$ 125.00	\$ -	\$ -	\$ 125.00	\$ -	100.00%
01-30-320-500175	Training/Education/Mtgs/Travel	\$ 9,350.00	\$ 77.93	\$ 77.93	\$ 9,272.07	\$ 2,385.00	73.66%
01-30-320-500176	District Professional Developm	\$ 19,000.00	\$ -	\$ -	\$ 19,000.00	\$ -	100.00%
01-30-320-500177	Gen Safety Training & Supplies	\$ 14,385.00	\$ 1,060.05	\$ 1,060.05	\$ 13,324.95	\$ -	92.63%
01-30-320-500180	Accrued Sick Leave Expense	\$ 3,066.00	\$ -	\$ 143.00	\$ 2,923.00	\$ -	95.34%
01-30-320-500185	Accrued Vacation Leave Expense	\$ 3,160.00	\$ -	\$ 117.00	\$ 3,043.00	\$ -	96.30%
	<b>Finance &amp; Admin Services Personnel</b>	<b>\$ 2,614,669.00</b>	<b>\$ 167,700.35</b>	<b>\$ 292,816.67</b>	<b>\$ 2,321,852.33</b>	<b>\$ 2,385.00</b>	<b>88.71%</b>
01-30-310-550006	Cashiering Shortages/Overages	\$ 50.00	\$ (0.33)	\$ 0.12	\$ 49.88	\$ -	99.76%
01-30-310-550018	Employee Medical/First Aid	\$ 300.00	\$ 1,371.00	\$ 1,371.00	\$ (1,071.00)	\$ -	-357.00%
01-30-310-550042	Office Supplies	\$ 13,315.00	\$ 477.56	\$ 2,915.48	\$ 10,399.52	\$ -	78.10%
01-30-310-550046	Office Equipment	\$ 5,000.00	\$ -	\$ -	\$ 5,000.00	\$ -	100.00%
01-30-310-550048	Postage	\$ 5,150.00	\$ 227.60	\$ 447.60	\$ 4,702.40	\$ -	91.31%
01-30-310-550066	Subscriptions	\$ 2,060.00	\$ -	\$ -	\$ 2,060.00	\$ -	100.00%
01-30-310-550072	Misc Operating Expenses	\$ 1,030.00	\$ -	\$ -	\$ 1,030.00	\$ -	100.00%
01-30-310-550078	Bad Debt Expense	\$ 3,000.00	\$ -	\$ -	\$ 3,000.00	\$ -	100.00%
01-30-310-550084	Depreciation	\$ 2,681,000.00	\$ 250,916.42	\$ 474,117.45	\$ 2,206,882.55	\$ -	82.32%
01-30-315-501511	Phones - 560 Magnolia	\$ 28,840.00	\$ 1,614.15	\$ 3,841.09	\$ 24,998.91	\$ -	86.68%
01-30-315-501531	Phones - 851 E. 6th	\$ 3,914.00	\$ 99.65	\$ 200.60	\$ 3,713.40	\$ -	94.87%
01-30-315-501561	Phones - 815 E. 12th	\$ 3,914.00	\$ 316.12	\$ 641.51	\$ 3,272.49	\$ -	83.61%
01-30-315-550044	Printing/Toner & Maint	\$ 17,510.00	\$ 1,847.75	\$ 3,709.29	\$ 13,800.71	\$ -	78.82%
01-30-320-550042	Office Supplies	\$ 2,000.00	\$ 405.06	\$ 463.75	\$ 1,536.25	\$ -	76.81%
	<b>Finance &amp; Admin Services Materials &amp; Supplies</b>	<b>\$ 2,767,083.00</b>	<b>\$ 257,274.98</b>	<b>\$ 487,707.89</b>	<b>\$ 2,279,375.11</b>	<b>\$ -</b>	<b>82.37%</b>
01-30-310-500190	Temporary Labor	\$ 25,000.00	\$ -	\$ -	\$ 25,000.00	\$ -	100.00%
01-30-310-550001	Bank/Financial Service Fees	\$ 20,600.00	\$ 686.34	\$ 1,527.84	\$ 19,072.16	\$ -	92.58%
01-30-310-550008	Transaction/Return Fees	\$ 3,090.00	\$ 89.38	\$ 157.31	\$ 2,932.69	\$ -	94.91%
01-30-310-550010	Transaction/Credit Card Fees	\$ 45,320.00	\$ 4,137.81	\$ 9,178.34	\$ 36,141.66	\$ -	79.75%
01-30-310-550014	Credit Check Fees	\$ 10,300.00	\$ 367.50	\$ 878.10	\$ 9,421.90	\$ -	91.47%
01-30-310-550030	Membership Dues	\$ 43,260.00	\$ 1,869.67	\$ 14,803.32	\$ 28,456.68	\$ -	65.78%
01-30-310-550036	Notary & Lien Fees	\$ 2,060.00	\$ 20.00	\$ 20.00	\$ 2,040.00	\$ -	99.03%
01-30-310-550050	Utility Billing Service	\$ 70,040.00	\$ 6,329.92	\$ 12,518.23	\$ 57,521.77	\$ -	82.13%
01-30-310-550051	Advertising/Legal Notices	\$ 4,120.00	\$ -	\$ -	\$ 4,120.00	\$ -	100.00%
01-30-310-550054	Property, Auto& Gen Liab Insur	\$ 82,400.00	\$ 7,411.09	\$ 14,822.18	\$ 67,577.82	\$ -	82.01%
01-30-310-580001	Accounting & Audit	\$ 36,050.00	\$ -	\$ -	\$ 36,050.00	\$ -	100.00%
01-30-310-580011	General Legal	\$ 154,500.00	\$ 3,295.00	\$ 3,295.00	\$ 151,205.00	\$ -	97.87%
01-30-310-580036	Other Professional Services	\$ 78,000.00	\$ 5,109.08	\$ 9,109.08	\$ 68,890.92	\$ 1,891.12	85.90%
01-30-315-550030	Membership Dues	\$ 2,060.00	\$ -	\$ -	\$ 2,060.00	\$ -	100.00%
01-30-315-580016	Computer Hardware	\$ 20,600.00	\$ 1,575.59	\$ 1,575.59	\$ 19,024.41	\$ -	92.35%
01-30-315-580021	IT/Software Support	\$ 5,150.00	\$ -	\$ -	\$ 5,150.00	\$ -	100.00%
01-30-315-580026	License/Maintenance/Support	\$ 150,000.00	\$ 25,357.39	\$ 44,901.24	\$ 105,098.76	\$ -	70.07%
01-30-320-550025	Employee Retention	\$ 2,500.00	\$ 145.20	\$ 145.20	\$ 2,354.80	\$ -	94.19%
01-30-320-550030	Membership Dues	\$ 1,470.00	\$ -	\$ -	\$ 1,470.00	\$ -	100.00%



Account Number	Description	Budget	Period Amt	End Bal	Variance	Encumbered	% Avail/ Uncollect
01-30-320-550051	Advertising/Legal Notices	\$ 1,000.00	\$ -	\$ 214.39	\$ 785.61	\$ -	78.56%
01-30-320-580036	Other Professional Services	\$ 37,000.00	\$ 2,625.00	\$ 2,625.00	\$ 34,375.00	\$ -	92.91%
	<b>Finance &amp; Admin Services Services</b>	<b>\$ 794,520.00</b>	<b>\$ 59,018.97</b>	<b>\$ 115,770.82</b>	<b>\$ 678,749.18</b>	<b>\$ 1,891.12</b>	<b>85.19%</b>
<b>Expense Total</b>	<b>FINANCE &amp; ADMIN SERVICES</b>	<b>\$ 6,176,272.00</b>	<b>\$ 483,994.30</b>	<b>\$ 896,295.38</b>	<b>\$ 5,279,976.62</b>	<b>\$ 4,276.12</b>	<b>85.42%</b>
<b>40</b>	<b>OPERATIONS</b>						
<b>410</b>	<b>Source of Supply Personnel</b>						
01-40-410-500105	Labor	\$ 359,300.00	\$ 18,762.99	\$ 28,573.49	\$ 330,726.51	\$ -	92.05%
01-40-410-500110	Overtime	\$ 19,656.00	\$ 46.70	\$ 2,118.13	\$ 17,537.87	\$ -	89.22%
01-40-410-500111	Double Time	\$ 1,713.00	\$ -	\$ -	\$ 1,713.00	\$ -	100.00%
01-40-410-500113	Standby/On-Call	\$ 9,800.00	\$ 700.00	\$ 1,050.00	\$ 8,750.00	\$ -	89.29%
01-40-410-500115	Social Security	\$ 27,487.00	\$ 1,316.91	\$ 2,153.23	\$ 25,333.77	\$ -	92.17%
01-40-410-500120	Medicare	\$ 6,434.00	\$ 307.97	\$ 533.59	\$ 5,900.41	\$ -	91.71%
01-40-410-500125	Health Insurance	\$ 130,680.00	\$ 7,577.91	\$ 14,940.47	\$ 115,739.53	\$ -	88.57%
01-40-410-500140	Life Insurance	\$ 2,412.00	\$ 98.34	\$ 189.00	\$ 2,223.00	\$ -	92.16%
01-40-410-500143	EAP Program	\$ 360.00	\$ 10.28	\$ 20.84	\$ 339.16	\$ -	94.21%
01-40-410-500145	Workers' Compensation	\$ 26,047.00	\$ 620.63	\$ 1,056.97	\$ 24,990.03	\$ -	95.94%
01-40-410-500150	Unemployment Insurance	\$ 53,173.00	\$ -	\$ -	\$ 53,173.00	\$ -	100.00%
01-40-410-500155	Retirement/CalPERS	\$ 89,944.00	\$ 4,697.70	\$ 8,235.08	\$ 81,708.92	\$ -	90.84%
01-40-410-500165	Uniforms & Employee Benefits	\$ 2,786.00	\$ -	\$ 200.00	\$ 2,586.00	\$ -	92.82%
01-40-410-500175	Training/Education/Mtgs/Travel	\$ 6,000.00	\$ -	\$ 1,920.00	\$ 4,080.00	\$ -	68.00%
01-40-410-500180	Accrued Sick Leave Expense	\$ 17,418.00	\$ 997.99	\$ 1,890.23	\$ 15,527.77	\$ -	89.15%
01-40-410-500185	Accrued Vacation Leave Expense	\$ 23,785.00	\$ 963.76	\$ 1,540.11	\$ 22,244.89	\$ -	93.52%
01-40-410-500187	Accrual Leave Payments	\$ 9,626.00	\$ -	\$ -	\$ 9,626.00	\$ -	100.00%
01-40-410-500195	CIP Related Labor	\$ (25,800.00)	\$ -	\$ -	\$ (25,800.00)	\$ -	100.00%
01-40-410-550024	Employment Testing	\$ 206.00	\$ -	\$ 75.00	\$ 131.00	\$ -	63.59%
<b>440</b>	<b>Transmission &amp; Distribution Personnel</b>						
01-40-440-500105	Labor	\$ 910,902.00	\$ 44,124.25	\$ 69,678.04	\$ 841,223.96	\$ -	92.35%
01-40-440-500110	Overtime	\$ 40,809.00	\$ 2,483.63	\$ 3,311.64	\$ 37,497.36	\$ -	91.89%
01-40-440-500111	Double Time	\$ 8,252.00	\$ 126.15	\$ 126.15	\$ 8,125.85	\$ -	98.47%
01-40-440-500113	Standby/On-Call	\$ 24,700.00	\$ 1,200.00	\$ 2,400.00	\$ 22,300.00	\$ -	90.28%
01-40-440-500115	Social Security	\$ 71,607.00	\$ 3,665.44	\$ 5,527.99	\$ 66,079.01	\$ -	92.28%
01-40-440-500120	Medicare	\$ 16,764.00	\$ 862.88	\$ 1,309.25	\$ 15,454.75	\$ -	92.19%
01-40-440-500125	Health Insurance	\$ 333,780.00	\$ 18,444.53	\$ 34,973.31	\$ 298,806.69	\$ -	89.52%
01-40-440-500140	Life Insurance	\$ 6,240.00	\$ 273.47	\$ 512.93	\$ 5,727.07	\$ -	91.78%
01-40-440-500143	EAP Program	\$ 918.00	\$ 31.80	\$ 60.28	\$ 857.72	\$ -	93.43%
01-40-440-500145	Workers' Compensation	\$ 51,086.00	\$ 1,373.40	\$ 2,041.60	\$ 49,044.40	\$ -	96.00%
01-40-440-500155	Retirement/CalPERS	\$ 203,424.00	\$ 12,521.00	\$ 21,021.57	\$ 182,402.43	\$ -	89.67%
01-40-440-500165	Uniforms & Employee Benefits	\$ 5,893.00	\$ 938.87	\$ 1,134.97	\$ 4,758.03	\$ -	80.74%
01-40-440-500175	Training/Education/Mtgs/Travel	\$ 3,090.00	\$ -	\$ 60.00	\$ 3,030.00	\$ -	98.06%
01-40-440-500180	Accrued Sick Leave Expense	\$ 49,544.00	\$ 3,542.73	\$ 4,279.19	\$ 45,264.81	\$ -	91.36%
01-40-440-500185	Accrued Vacation Leave Expense	\$ 66,253.00	\$ 2,768.88	\$ 6,971.95	\$ 59,281.05	\$ -	89.48%
01-40-440-500187	Accrual Leave Payments	\$ 46,097.00	\$ -	\$ -	\$ 46,097.00	\$ -	100.00%
01-40-440-500195	CIP Related Labor	\$ (61,920.00)	\$ (1,290.42)	\$ (1,323.47)	\$ (60,596.53)	\$ -	97.86%
01-40-440-550024	Employment Testing	\$ 412.00	\$ -	\$ -	\$ 412.00	\$ -	100.00%
<b>450</b>	<b>Inspections Personnel</b>						
01-40-450-500105	Labor	\$ 41,427.00	\$ 606.35	\$ 606.35	\$ 40,820.65	\$ -	98.54%
01-40-450-500110	Overtime	\$ 7,204.00	\$ 78.54	\$ 78.54	\$ 7,125.46	\$ -	98.91%
01-40-450-500111	Double Time	\$ 394.00	\$ -	\$ -	\$ 394.00	\$ -	100.00%
01-40-450-500115	Social Security	\$ 3,041.00	\$ 42.78	\$ 42.78	\$ 2,998.22	\$ -	98.59%
01-40-450-500120	Medicare	\$ 712.00	\$ 10.01	\$ 10.01	\$ 701.99	\$ -	98.59%
01-40-450-500125	Health Insurance	\$ 12,552.00	\$ 102.82	\$ 221.24	\$ 12,330.76	\$ -	98.24%
01-40-450-500140	Life Insurance	\$ 276.00	\$ 0.92	\$ 1.99	\$ 274.01	\$ -	99.28%
01-40-450-500143	EAP Program	\$ 34.00	\$ 0.12	\$ 0.25	\$ 33.75	\$ -	99.26%
01-40-450-500145	Workers' Compensation	\$ 2,924.00	\$ 11.62	\$ 11.62	\$ 2,912.38	\$ -	99.60%
01-40-450-500155	Retirement/CalPERS	\$ 12,292.00	\$ 253.83	\$ 401.51	\$ 11,890.49	\$ -	96.73%
<b>460</b>	<b>Customer Svc &amp; Meter Reading Personnel</b>						
01-40-460-500105	Labor	\$ 173,375.00	\$ 11,902.83	\$ 20,411.85	\$ 152,963.15	\$ -	88.23%
01-40-460-500110	Overtime	\$ 13,807.00	\$ 689.67	\$ 800.00	\$ 13,007.00	\$ -	94.21%
01-40-460-500111	Double Time	\$ 2,152.00	\$ -	\$ -	\$ 2,152.00	\$ -	100.00%
01-40-460-500115	Social Security	\$ 14,222.00	\$ 856.49	\$ 1,423.46	\$ 12,798.54	\$ -	89.99%
01-40-460-500120	Medicare	\$ 3,330.00	\$ 206.01	\$ 338.59	\$ 2,991.41	\$ -	89.83%
01-40-460-500125	Health Insurance	\$ 78,408.00	\$ 4,246.14	\$ 10,603.07	\$ 67,804.93	\$ -	86.48%
01-40-460-500140	Life Insurance	\$ 1,140.00	\$ 47.10	\$ 114.76	\$ 1,025.24	\$ -	89.93%
01-40-460-500143	EAP Program	\$ 216.00	\$ 5.87	\$ 15.18	\$ 200.82	\$ -	92.97%
01-40-460-500145	Workers' Compensation	\$ 12,236.00	\$ 415.80	\$ 686.61	\$ 11,549.39	\$ -	94.39%
01-40-460-500155	Retirement/CalPERS	\$ 47,651.00	\$ 3,159.30	\$ 5,436.13	\$ 42,214.87	\$ -	88.59%
01-40-460-500165	Uniforms & Employee Benefits	\$ 1,600.00	\$ -	\$ -	\$ 1,600.00	\$ -	100.00%
01-40-460-500175	Training/Education/Mtgs/Travel	\$ 412.00	\$ -	\$ -	\$ 412.00	\$ -	100.00%
01-40-460-500180	Accrued Sick Leave Expense	\$ 7,934.00	\$ 1,269.08	\$ 1,269.08	\$ 6,664.92	\$ -	84.00%

Account Number	Description	Budget	Period Amt	End Bal	Variance	Encumbered	% Avail/ Uncollect
01-40-460-500185	Accrued Vacation Leave Expense	\$ 14,722.00	\$ 196.35	\$ 719.95	\$ 14,002.05	\$ -	95.11%
01-40-460-500187	Accrual Leave Payments	\$ 17,029.00	\$ -	\$ -	\$ 17,029.00	\$ -	100.00%
01-40-460-500195	CIP Related Labor	\$ (10,320.00)	\$ (459.32)	\$ (459.32)	\$ (9,860.68)	\$ -	95.55%
01-40-460-550024	Employment Testing	\$ 206.00	\$ -	\$ -	\$ 206.00	\$ -	100.00%
<b>470</b>	<b>Maintenance &amp; General Plant Personnel</b>						
01-40-470-500105	Labor	\$ 43,917.00	\$ 2,627.50	\$ 9,805.58	\$ 34,111.42	\$ -	77.67%
01-40-470-500110	Overtime	\$ 3,616.00	\$ -	\$ -	\$ 3,616.00	\$ -	100.00%
01-40-470-500111	Double Time	\$ 482.00	\$ -	\$ -	\$ 482.00	\$ -	100.00%
01-40-470-500115	Social Security	\$ 2,981.00	\$ 162.90	\$ 608.39	\$ 2,372.61	\$ -	79.59%
01-40-470-500120	Medicare	\$ 700.00	\$ 38.11	\$ 142.29	\$ 557.71	\$ -	79.67%
01-40-470-500125	Health Insurance	\$ 19,620.00	\$ 1,865.16	\$ 3,363.07	\$ 16,256.93	\$ -	82.86%
01-40-470-500140	Life Insurance	\$ 312.00	\$ 21.16	\$ 37.80	\$ 274.20	\$ -	87.88%
01-40-470-500143	EAP Program	\$ 53.00	\$ 3.33	\$ 6.26	\$ 46.74	\$ -	88.19%
01-40-470-500145	Workers' Compensation	\$ 3,102.00	\$ 74.48	\$ 286.99	\$ 2,815.01	\$ -	90.75%
01-40-470-500155	Retirement/CalPERS	\$ 10,963.00	\$ 508.10	\$ 1,629.37	\$ 9,333.63	\$ -	85.14%
	<b>Operations Personnel</b>	<b>\$ 3,083,600.00</b>	<b>\$ 156,110.84</b>	<b>\$ 275,194.94</b>	<b>\$ 2,808,405.06</b>	<b>\$ -</b>	<b>91.08%</b>
<b>410</b>	<b>Source of Supply Materials &amp; Supplies</b>						
01-40-410-501101	Electricity - Wells	\$ 1,635,854.00	\$ 97,828.38	\$ 182,888.52	\$ 1,452,965.48	\$ -	88.82%
01-40-410-501201	Gas - Wells	\$ 225.00	\$ 14.79	\$ 30.57	\$ 194.43	\$ -	86.41%
01-40-410-510011	Treatment & Chemicals	\$ 90,000.00	\$ 1,197.00	\$ 1,197.00	\$ 88,803.00	\$ 18,059.52	78.60%
01-40-410-510021	Lab Testing	\$ 90,000.00	\$ 2,184.00	\$ 4,494.00	\$ 85,506.00	\$ -	95.01%
01-40-410-510031	Small Tools, Parts & Maint	\$ 7,200.00	\$ 385.13	\$ 460.59	\$ 6,739.41	\$ -	93.60%
01-40-410-520021	Maint & Rpr-Telemetry Equip	\$ 10,300.00	\$ -	\$ -	\$ 10,300.00	\$ -	100.00%
01-40-410-520031	Maint & Rpr-General Equipment	\$ -	\$ 44.86	\$ 44.86	\$ (44.86)	\$ -	0.00%
01-40-410-520061	Maint & Rpr-Pumping Equipment	\$ 128,750.00	\$ 7,481.24	\$ 7,765.58	\$ 120,984.42	\$ 5,074.96	90.03%
01-40-410-550066	Subscriptions	\$ 3,000.00	\$ -	\$ 1,070.00	\$ 1,930.00	\$ -	64.33%
<b>440</b>	<b>Transmission &amp; Distribution Materials &amp; Supplies</b>						
01-40-440-510031	Small Tools, Parts & Maint	\$ 16,500.00	\$ 804.13	\$ 1,278.65	\$ 15,221.35	\$ -	92.25%
01-40-440-520071	Maint & Rpr-Pipelines&Hydrants	\$ 80,000.00	\$ 6,506.95	\$ 8,415.63	\$ 71,584.37	\$ -	89.48%
01-40-440-520081	Maint & Rpr-Pressure Regulatrs	\$ 7,725.00	\$ -	\$ -	\$ 7,725.00	\$ -	100.00%
01-40-440-540001	Backflow Program	\$ 7,725.00	\$ -	\$ 182.10	\$ 7,542.90	\$ -	97.64%
01-40-440-540024	Inventory Adjustments	\$ 3,090.00	\$ -	\$ -	\$ 3,090.00	\$ -	100.00%
01-40-440-540036	Line Locates	\$ 3,605.00	\$ 249.25	\$ 465.50	\$ 3,139.50	\$ -	87.09%
01-40-440-540042	Meters Maintenance & Services	\$ 154,500.00	\$ 13,807.33	\$ 21,985.10	\$ 132,514.90	\$ 7.33	85.77%
01-40-440-540078	Reservoirs Maintenance	\$ 54,500.00	\$ -	\$ -	\$ 54,500.00	\$ -	100.00%
<b>470</b>	<b>Maintenance &amp; General Plant Materials &amp; Supplies</b>						
01-40-470-501111	Electricity - 560 Magnolia	\$ 28,016.00	\$ 1,366.95	\$ 2,883.23	\$ 25,132.77	\$ -	89.71%
01-40-470-501121	Electricity - 12303 Oak Glen	\$ 2,575.00	\$ 316.39	\$ 666.16	\$ 1,908.84	\$ -	74.13%
01-40-470-501131	Electricity - 13695 Oak Glen	\$ 1,904.00	\$ 92.66	\$ 194.70	\$ 1,709.30	\$ -	89.77%
01-40-470-501141	Electricity - 13697 Oak Glen	\$ 2,903.00	\$ 148.66	\$ 323.01	\$ 2,579.99	\$ -	88.87%
01-40-470-501151	Elec - 9781 Avenida Miravilla	\$ 1,890.00	\$ 76.47	\$ 162.10	\$ 1,727.90	\$ -	91.42%
01-40-470-501161	Electricity - 815 E. 12th	\$ 6,180.00	\$ 351.20	\$ 817.87	\$ 5,362.13	\$ -	86.77%
01-40-470-501171	Electricity - 851 E. 6th	\$ 4,200.00	\$ 157.61	\$ 305.43	\$ 3,894.57	\$ -	92.73%
01-40-470-501321	Propane - 12303 Oak Glen	\$ 118.00	\$ -	\$ -	\$ 118.00	\$ -	100.00%
01-40-470-501331	Propane - 13695 Oak Glen	\$ 2,000.00	\$ 229.62	\$ 229.62	\$ 1,770.38	\$ -	88.52%
01-40-470-501341	Propane - 13697 Oak Glen	\$ 2,000.00	\$ 351.07	\$ 351.07	\$ 1,648.93	\$ -	82.45%
01-40-470-501351	Propane-9781 Avenida Miravilla	\$ 1,600.00	\$ 471.83	\$ 471.83	\$ 1,128.17	\$ -	70.51%
01-40-470-501411	Sanitation - 560 Magnolia	\$ 2,987.00	\$ 325.90	\$ 531.21	\$ 2,455.79	\$ -	82.22%
01-40-470-501461	Sanitation - 815 E. 12th	\$ 4,172.00	\$ 398.86	\$ 797.72	\$ 3,374.28	\$ -	80.88%
01-40-470-501471	Sanitation - 11083 Cherry Ave	\$ 3,296.00	\$ 814.41	\$ 1,085.88	\$ 2,210.12	\$ -	67.05%
01-40-470-501611	Maint & Repair- 560 Magnolia	\$ 25,000.00	\$ 1,429.20	\$ 4,103.63	\$ 20,896.37	\$ -	83.59%
01-40-470-501621	Maint & Repair- 12303 Oak Glen	\$ 1,236.00	\$ -	\$ -	\$ 1,236.00	\$ -	100.00%
01-40-470-501631	Maint & Repair- 13695 Oak Glen	\$ 1,200.00	\$ -	\$ -	\$ 1,200.00	\$ -	100.00%
01-40-470-501641	Maint & Repair- 13697 Oak Glen	\$ 1,200.00	\$ -	\$ -	\$ 1,200.00	\$ -	100.00%
01-40-470-501651	Maint & Rpr-9781 Ave Miravilla	\$ 1,545.00	\$ -	\$ -	\$ 1,545.00	\$ -	100.00%
01-40-470-501661	Maint & Repair- 815 E. 12th	\$ 5,150.00	\$ 287.66	\$ 581.05	\$ 4,568.95	\$ -	88.72%
01-40-470-501671	Maint & Repair- 851 E. 6th	\$ 1,500.00	\$ 160.00	\$ 365.86	\$ 1,134.14	\$ -	75.61%
01-40-470-501691	Maint & Rpr- Buildgs (General)	\$ 20,000.00	\$ 2,051.60	\$ 2,129.40	\$ 17,870.60	\$ (91.02)	89.81%
01-40-470-510001	Auto/Fuel	\$ 82,000.00	\$ 6,427.80	\$ 12,273.71	\$ 69,726.29	\$ -	85.03%
01-40-470-520011	Maint & Rpr-Safety Equipment	\$ 17,510.00	\$ 17.76	\$ 4,491.51	\$ 13,018.49	\$ -	74.35%
01-40-470-520031	Maint & Rpr-General Equipment	\$ 47,380.00	\$ 736.39	\$ 6,249.49	\$ 41,130.51	\$ 2,787.98	80.93%
01-40-470-520041	Maint & Rpr-Fleet	\$ 51,500.00	\$ 3,043.41	\$ 5,016.68	\$ 46,483.32	\$ -	90.26%
01-40-470-520091	Maint & Rpr-Communicatn Equip	\$ 5,665.00	\$ -	\$ -	\$ 5,665.00	\$ -	100.00%
	<b>Operations Materials &amp; Supplies</b>	<b>\$ 2,617,701.00</b>	<b>\$ 149,758.51</b>	<b>\$ 274,309.26</b>	<b>\$ 2,343,391.74</b>	<b>\$ 25,838.77</b>	<b>88.53%</b>
<b>410</b>	<b>Source of Supply Services</b>						
01-40-410-500501	State Project Water Purchases	\$ 3,752,050.00	\$ 823,536.00	\$ 823,536.00	\$ 2,928,514.00	\$ -	78.05%
01-40-410-540084	State Mandates & Tariffs	\$ 72,100.00	\$ 5,130.94	\$ 18,699.99	\$ 53,400.01	\$ -	74.06%
<b>440</b>	<b>Transmission &amp; Distribution Services</b>						
01-40-440-550051	Advertising/Legal Notices	\$ 4,000.00	\$ 1,290.00	\$ 1,680.00	\$ 2,320.00	\$ -	58.00%



Account Number	Description	Budget	Period Amt	End Bal	Variance	Encumbered	% Avail/ Uncollect
<b>470</b>	<b>Maintenance &amp; General Plant Services</b>						
01-40-470-540030	Landscape Maintenance	\$ 82,000.00	\$ 8,775.00	\$ 8,794.63	\$ 73,205.37	\$ -	89.27%
01-40-470-540072	Rechrg Facs, Cnyns&Ponds Maint	\$ 178,440.00	\$ 3,401.86	\$ 44,292.92	\$ 134,147.08	\$ -	75.18%
	<b>Operations Services</b>	<b>\$ 4,088,590.00</b>	<b>\$ 842,133.80</b>	<b>\$ 897,003.54</b>	<b>\$ 3,191,586.46</b>	<b>\$ -</b>	<b>78.06%</b>
<b>Expense Total</b>	<b>OPERATIONS</b>	<b>\$ 9,789,891.00</b>	<b>\$ 1,148,003.15</b>	<b>\$ 1,446,507.74</b>	<b>\$ 8,343,383.26</b>	<b>\$ 25,838.77</b>	<b>84.96%</b>
<b>50</b>	<b>GENERAL</b>						
01-50-510-502001	Rents/Leases	\$ 24,580.00	\$ 2,025.00	\$ 4,050.00	\$ 20,530.00	\$ -	83.52%
01-50-510-510031	Small Tools, Parts & Maint	\$ 515.00	\$ -	\$ -	\$ 515.00	\$ -	100.00%
01-50-510-540066	Property Damages & Theft	\$ 15,450.00	\$ -	\$ -	\$ 15,450.00	\$ -	100.00%
01-50-510-550040	General Supplies	\$ 11,330.00	\$ 1,664.16	\$ 3,087.79	\$ 8,242.21	\$ -	72.75%
01-50-510-550060	Public Ed./Community Outreach	\$ 137,000.00	\$ 1,065.00	\$ 43,035.98	\$ 93,964.02	\$ -	68.59%
01-50-510-550072	Misc Operating Expenses	\$ 1,030.00	\$ -	\$ -	\$ 1,030.00	\$ -	100.00%
	<b>General Materials &amp; Supplies</b>	<b>\$ 189,905.00</b>	<b>\$ 4,754.16</b>	<b>\$ 50,173.77</b>	<b>\$ 139,731.23</b>	<b>\$ -</b>	<b>73.58%</b>
01-50-510-550096	Beaumont Basin Watermaster	\$ 43,260.00	\$ -	\$ 23,498.00	\$ 19,762.00	\$ -	45.68%
01-50-510-550097	SAWPA Basin Monitoring Program	\$ 19,000.00	\$ -	\$ -	\$ 19,000.00	\$ -	100.00%
	<b>General Services</b>	<b>\$ 62,260.00</b>	<b>\$ -</b>	<b>\$ 23,498.00</b>	<b>\$ 38,762.00</b>	<b>\$ -</b>	<b>62.26%</b>
<b>Expense Total</b>	<b>GENERAL</b>	<b>\$ 252,165.00</b>	<b>\$ 4,754.16</b>	<b>\$ 73,671.77</b>	<b>\$ 178,493.23</b>	<b>\$ -</b>	<b>70.78%</b>
<b>Expense Total</b>	<b>ALL EXPENSES</b>	<b>\$ 17,014,195.00</b>	<b>\$ 1,662,081.75</b>	<b>\$ 2,467,659.85</b>	<b>\$ 14,546,535.15</b>	<b>\$ 30,114.89</b>	<b>85.32%</b>



**Beaumont-Cherry Valley Water District  
Cash Balance & Investment Report  
As of February 29, 2020**

Account Name	Wells Fargo	Account Ending #	Cash Balance per Account	
			Balance	Prior Month Balance
General		4152	\$974,787.52	\$771,815.15
<b>Total Cash</b>			<b>\$974,787.52</b>	<b>\$771,815.15</b>

Account Name	Market Value	Prior Month Balance	Actual % of Total	Policy % Limit	Maturity	Par Amount	Rate	2020 Interest to Date
C-s. State Treasurer's Office: Local Agency Investment Fund	\$24,718,151.66	\$24,718,151.66	40%	No Limit	Liquid	N/A	1.86	\$138,560.57 (1)
CallTRUST Short Term Fund	\$36,474,024.66	\$36,350,902.42	60%	No Limit	Liquid	N/A	1.78	\$108,847.67
<b>Total Investments</b>	<b>\$61,192,176.32</b>	<b>\$61,069,054.08</b>						<b>\$247,408.24</b>

**Total Cash & Investments \$ 62,166,963.84 \$ 61,840,869.23**

The investments above are in accordance with the District's investment policy: *[Signature]* 3/19/2020

BCVWD will be able to meet its cash flow obligations for the next 6 months. *[Signature]* 3/19/2020

(1) 4th Quarter 2019 interest received in 2020

# Accounts Payable

## Checks by Date - Detail by Check Date

User: wclayton  
 Printed: 3/26/2020 11:59 AM

### Beaumont-Cherry Valley Water District

560 Magnolia Avenue  
 Beaumont CA 92223  
 (951) 845-9581  
 www.bcvwd.org



Check No	Vendor No Invoice No	Vendor Name Description	Check Date Reference	Void Checks	Check Amount
ACH	10085	CalPERS Retirement System	03/05/2020		
	15917231	PR Batch 00001.03.2020 CalPERS 8% ER Paid			1,208.64
	15917231	PR Batch 00001.03.2020 CalPERS ER Paid Classic			9,238.59
	15917231	PR Batch 00001.03.2020 CalPERS 8% EE Paid			2,248.53
	15917231	PR Batch 00001.03.2020 CalPERS 7.5% EE PEPRA			3,076.74
	15917231	PR Batch 00001.03.2020 CalPERS 1% ER Paid			179.79
	15917231	PR Batch 00001.03.2020 CalPERS ER PEPRA			3,088.22
	15917231	PR Batch 00001.03.2020 CalPERS 7% EE Deduction			1,258.62
Total for this ACH Check for Vendor 10085:				0.00	20,299.13
ACH	10087	EDD	03/05/2020		
	0-702-191-648	PR Batch 00002.03.2020 State Income Tax			342.51
	0-702-191-648	PR Batch 00001.03.2020 State Income Tax			4,168.52
	0-702-191-648	PR Batch 00002.03.2020 CA SDI			33.44
	0-702-191-648	PR Batch 00001.03.2020 CA SDI			1,050.37
Total for this ACH Check for Vendor 10087:				0.00	5,594.84
ACH	10094	U.S. Treasury	03/05/2020		
	32873002	PR Batch 00002.03.2020 Federal Income Tax			736.58
	32873002	PR Batch 00001.03.2020 FICA Employer Portion			6,568.43
	32873002	PR Batch 00002.03.2020 FICA Employer Portion			207.58
	32873002	PR Batch 00002.03.2020 Medicare Employer Portion			48.55
	32873002	PR Batch 00001.03.2020 Medicare Employer Portion			1,538.77
	32873002	PR Batch 00002.03.2020 Medicare Employee Portion			48.55
	32873002	PR Batch 00001.03.2020 Federal Income Tax			11,554.05
	32873002	PR Batch 00001.03.2020 FICA Employee Portion			6,568.43
	32873002	PR Batch 00002.03.2020 FICA Employee Portion			207.58
	32873002	PR Batch 00001.03.2020 Medicare Employee Portion			1,538.77
Total for this ACH Check for Vendor 10094:				0.00	29,017.29
ACH	10141	Ca State Disbursement Unit	03/05/2020		
	HNFBHAX6657	PR Batch 00001.03.2020 Garnishment			360.05
	HNFBHAX6657	PR Batch 00001.03.2020 Garnishment			288.46
Total for this ACH Check for Vendor 10141:				0.00	648.51
ACH	10203	Voya Financial	03/05/2020		
	VB1450-PP05	PR Batch 00001.03.2020 Deferred Comp			475.00
Total for this ACH Check for Vendor 10203:				0.00	475.00
ACH	10264	CalPERs Supplemental Income Plans	03/05/2020		
	15970004	PR Batch 00001.03.2020 457 Loan Repayment			177.19
	15970004	PR Batch 00001.03.2020 CalPERS 457			640.00
	15970004	PR Batch 00001.03.2020 CalPERS 457 %			130.84
Total for this ACH Check for Vendor 10264:				0.00	948.03

Check No	Vendor No Invoice No	Vendor Name Description	Check Date Reference	Void Checks	Check Amount
ACH	10087 0-524-998-688 0-524-998-688	EDD PR Batch 00003.03.2020 CA SDI PR Batch 00003.03.2020 State Income Tax	03/05/2020		11.77 498.95
Total for this ACH Check for Vendor 10087:				0.00	510.72
ACH	10094 62112774 62112774 62112774 62112774 62112774	U.S. Treasury PR Batch 00003.03.2020 FICA Employee Portion PR Batch 00003.03.2020 Medicare Employer Portion PR Batch 00003.03.2020 FICA Employer Portion PR Batch 00003.03.2020 Federal Income Tax PR Batch 00003.03.2020 Medicare Employee Portion	03/05/2020		379.65 88.79 379.65 1,188.83 88.79
Total for this ACH Check for Vendor 10094:				0.00	2,125.71
9995	10099 23000 23026	A & A Fence Co. Inc. (2) Gates for Cherry and International Rd Tension Bands/Brace Bands/Ball Caps - Cherry/International Rd	03/05/2020		538.75 8.62
Total for Check Number 9995:				0.00	547.37
9996	10319 03012020	ACWA Joint Powers Insurance Authority (35) Employee Assistance Program - March 2020	03/05/2020		89.95
Total for Check Number 9996:				0.00	89.95
9997	10144 LYUM1439335 LYUM1440114 LYUM1440114 LYUM1443208 LYUM1443210	Alsco Inc. Cleaning of Mats & Shop Towels 12th/Palm - Feb 2020 Case - Gloves - District Wide Cleaning of 3 Office Mats 560 Magnolia - Feb 2020 Cleaning of Mats & Shop Towels 12th/Palm - Feb 2020 Cleaning of 3 Office Mats 560 Magnolia - Feb 2020	03/05/2020		17.35 94.69 16.34 26.96 20.95
Total for Check Number 9997:				0.00	176.29
9998	10695 2684 2684 2684	B-81 Paving Inc. (5) Service Relocation - Btw 9th/10th on Magnolia (2) Districtwide Repairs - Meter Service Lines (6) Districtwide Repairs - Main Line	03/05/2020		5,959.50 2,697.00 5,031.50
Total for Check Number 9998:				0.00	13,688.00
9999	10283 01022020 03042020	BCVWD Custodian of Petty Cash Brita Filters - 560 Magnolia Postage - Certified Letter - 560 Magnolia	03/05/2020		31.31 7.60
Total for Check Number 9999:				0.00	38.91
10000	10774 161818 161819	Jesus Camacho (18) Truck Washes - March 2020 (3) Truck Washes - March 2020	03/05/2020		190.00 30.00
Total for Check Number 10000:				0.00	220.00
10001	10822 21121229 21121229 21121229 21121230 21121230 21121230	Canon Financial Services, Inc. Contract Charge - 2/1 - 2/29/2020 - 560 Magnolia - Feb 2020 BW Meter Usage - 1/1/ - 1/31/2020 - 560 Magnolia - Jan 2020 CLR Meter Usage - 1/1/ - 1/31/2020 - 560 Magnolia - Jan 2020 CLR Meter Usage - 1/1 - 1/31/2020 - 12th/Palm - Jan 2020 BW Meter Usage - 1/1 - 1/31/2020 - 12th/Palm - Jan 2020 Contract Charge - 2/1 - 02/29/2020 - 12th/Palm - Feb 2020	03/05/2020		329.33 48.57 798.84 32.33 7.97 235.78
Total for Check Number 10001:				0.00	1,452.82

Check No	Vendor No Invoice No	Vendor Name Description	Check Date Reference	Void Checks	Check Amount
10002	10351 02202020	Cherry Valley Nursery & Landscape Supply Service Relocation - Replace Sod - 961 Magnolia	03/05/2020		26.94
Total for Check Number 10002:				0.00	26.94
10003	10853 101217	Chr Services INC Defibrillator/Cabinets/Wall Sign/Carry Cases - 560 Magnolia	03/05/2020		1,371.00
Total for Check Number 10003:				0.00	1,371.00
10004	10854 02122020 022020 022020	Sabrina Foley Eng. Week 2020 - Employee Retention - Water Bottles/Notebooks IE SHRM Chapter Mtg - Feb 2020 - S Foley Mileage - IE SHRM Chapter Mtg - Feb 2020 - S Foley	03/05/2020		145.20 40.00 37.93
Total for Check Number 10004:				0.00	223.13
10005	10600 03022020	Gaucho Gophers & Landscape Management NCR 1 Rodent Control - Feb 2020	03/05/2020		1,000.00
Total for Check Number 10005:				0.00	1,000.00
10006	10321 02262020	Julian Herrera Jr Safety Boots - J Herrera	03/05/2020		175.80
Total for Check Number 10006:				0.00	175.80
10007	10465 25AR1103817 25AR1103817	Image Source Xerox 3610 Contract Charges 3/1 - 3/31/2020 - March 2020 Xerox 3610 Usage Charges 2/1 - 2/29/2020 - Feb 2020	03/05/2020		71.71 87.06
Total for Check Number 10007:				0.00	158.77
10008	10273 S1031710.002 S1032011.001 S1032011.001 S1032668.001 S1032668.001 S1032668.001 S1032668.001	Inland Water Works Supply Co. (4) 635 Full Circles - Inventory (3) Saddles 980 x 1" Out - Inventory (5) Saddles 980 x 1" Out Brass DNI (3) 1320 Meter Lids - Inventory (18) 1320 Meter Boxes - Inventory (3) 1015 Meter Boxes - Inventory (18) 1015 Meter Lids - Inventory	03/05/2020		369.96 133.18 779.28 31.68 133.05 380.14 190.07
Total for Check Number 10008:				0.00	2,017.36
10009	10809 962	Inner-City Auto Repair & Tires Oil/Filter - OD 13,473 Unit 38	03/05/2020		54.39
Total for Check Number 10009:				0.00	54.39
10010	10545 546669	Itron, Inc. (1) Itron Wireless Handheld Maint Annual Renewal	03/05/2020		4,003.95
Total for Check Number 10010:				0.00	4,003.95
10011	10496 S82401	John Borden Heating & Air Conditioning Install 4 Ton AC Unit/Condenser Pad/Switches - 560 Magnolia	03/05/2020		9,150.00
Total for Check Number 10011:				0.00	9,150.00

Check No	Vendor No Invoice No	Vendor Name Description	Check Date Reference	Void Checks	Check Amount
10012	10281	Luther's Truck and Equipment	03/05/2020		
	44011	Bumper/Bolts/Washers/Ties/Nylocks - Dump Truck			745.58
	44011	Labor - Replace Bumper - Dump Truck			308.00
Total for Check Number 10012:				0.00	1,053.58
10013	10278	MetLife - Group Benefits	03/05/2020		
	KM05754034 March	MetLife Dental Ins - March 2020			944.48
	KM05754034 March	MetLife Vision Ins - March 2020			232.15
Total for Check Number 10013:				0.00	1,176.63
10014	10389	Jaime Munoz	03/05/2020		
	5133028	Safety Boots - J Munoz			163.07
Total for Check Number 10014:				0.00	163.07
10015	10756	Cole Nyberg	03/05/2020		
	02282020	Safety Boots - C Nyberg			200.00
Total for Check Number 10015:				0.00	200.00
10016	10765	Brian Ortega	03/05/2020		
	02212020	Safety Boots - B Ortega			200.00
Total for Check Number 10016:				0.00	200.00
10017	10045	Pacific Alarm Service Inc.	03/05/2020		
	R154369	Alarm Equip/Rent/Service/Monitor - 560 Magnolia			411.13
	R154370	Alarm Equip/Rent/Service/Monitor - 11083 Cherry Av			59.50
Total for Check Number 10017:				0.00	470.63
10018	10102	Pat's Pots	03/05/2020		
	17864	Labor - Rental Portable Toilets - 1/14 - 2/10/2020			245.20
	17864	Rental Portable Toilet - 1/14 - 2/10/2020			64.80
	17865	Rental Portable Toilet - 2/11 - 3/9/2020			64.80
	17865	Labor - Rental Portable Toilets - 2/11 - 3/9/2020			245.20
Total for Check Number 10018:				0.00	620.00
10019	10797	Raftelis Financial Consultants, Inc.	03/05/2020		
	14282	Fees for Water Rate Study 2019 - Final Billing Jan 2020			1,109.08
Total for Check Number 10019:				0.00	1,109.08
10020	10056	RDO Equipment Co. Trust# 80-5800	03/05/2020		
	P6082235	(1) Replace Seat on Green Tractor			341.50
Total for Check Number 10020:				0.00	341.50
10021	10629	Redlands Ford	03/05/2020		
	01222020	Oil/Gaskets/Air Cleaner - OD 74,623 Unit 5			152.19
	01222020	Labor - Install/Change Air Cleaner/Gasket/Oil - OD 74,623 Unit 5			452.22
	02252020	Labor - Perform Multipoint Inspections - OD 74,623 Unit 5			0.01
	02252020	Coolant Hose/Clamp - OD 74,623 Unit 5			78.53
Total for Check Number 10021:				0.00	682.95
10022	10317	Robertson's Ready Mix	03/05/2020		
	645958	26.06 Tons of Sand - Beaumont Ave Capital Replacement Job			386.00
	645958	25 Tons of Base - Beaumont Ave Capital Replacement Job			346.69
Total for Check Number 10022:				0.00	732.69



Check No	Vendor No Invoice No	Vendor Name Description	Check Date Reference	Void Checks	Check Amount
10023	10689 179741 179750 180345	Safety Compliance Company Safety Meeting - Lockout/Tagout/Blockout - Field Staff Safety Meeting - Emerge Action/Fire Prevention - All Employees Safety Meeting - Traffic Control/Flaggers - Field Staff	03/05/2020		250.00 250.00 250.00
Total for Check Number 10023:				0.00	750.00
10024	10830 0758916-IN	SC Fuels (60) 5 Gallon Drums AW 68-5GPL - District Wells	03/05/2020		625.68
Total for Check Number 10024:				0.00	625.68
10025	10042 07132135000Feb	Southern California Gas Company Monthly Gas Charges 1/27 - 2/26/2020 Feb 2020	03/05/2020		14.79
Total for Check Number 10025:				0.00	14.79
10026	10276 00610763 March	Standard Insurance Company Monthly Life & AD&D Ins - March 2020	03/05/2020		893.70
Total for Check Number 10026:				0.00	893.70
10027	10031 3438942086 3438942087 3439513483 3439513484 3439513484 3439513485 3439513486 3440849993 3440849993	Staples Business Advantage Black Ink - 560 Magnolia Pens/Hole Punch - 560 Magnolia Pens/Binders/Tape/Correction Tape - 560 Magnolia Headset - 560 Magnolia Black Ink - 560 Magnolia Speaker - HR Adapter - HR Index 8 Tabs - HR Form Holders/Staples/Scissors - 560 Magnolia	03/05/2020		141.78 67.46 119.52 30.37 75.61 28.97 30.81 122.29 118.08
Total for Check Number 10027:				0.00	734.89
10028	10063 01312020	The Record Gazette Notice of Inviting Proposals - Reservoir Cleaning	03/05/2020		390.00
Total for Check Number 10028:				0.00	390.00
10029	10743 15726	Townsend Public Affairs, Inc. Consulting Services - March 2020	03/05/2020		4,000.00
Total for Check Number 10029:				0.00	4,000.00
10030	10284 220200046 220200046	Underground Service Alert of Southern California 145 New Ticket Charges Oct 2019 Monthly Maintenance Fee	03/05/2020		239.25 10.00
Total for Check Number 10030:				0.00	249.25
10031	10255 0409967-IN 0410224-IN 049968-IN	Unlimited Services Building Maintenance March 2020 Janitorial Services - 815 E 12th March 2020 Janitorial Services - 851 E 6th March 2020 Janitorial Services - 560 Magnolia Av	03/05/2020		150.00 160.00 845.00
Total for Check Number 10031:				0.00	1,155.00

Check No	Vendor No Invoice No	Vendor Name Description	Check Date Reference	Void Checks	Check Amount
10032	10778	Urban Habitat	03/05/2020		
	5392	Well Site 3			420.00
	5392	2850 Pressure Zone Reservoir (Cherry Tank)			930.00
	5392	Well Site 2			330.00
	5392	Well Site 25			120.00
	5392	2650 Pressure Zone Reservoir (Hannon Tank)			900.00
	5392	BCVWD Business Office			150.00
	5392	Well Site 16			345.00
	5392	2850 Pressure Zone Reservoir (Vineland Tank)			540.00
	5392	Well Site 24			330.00
	5392	Well Site 29			240.00
	5392	Well Site 22			510.00
Total for Check Number 10032:				0.00	4,815.00
10033	10385 5484419	Waterline Technologies, Inc. - PSOC (900) Gallons Chlorine - Well 25	03/05/2020		1,197.00
Total for Check Number 10033:				0.00	1,197.00
10034	UB*03708	William Lyons Or RSI Communities LLC Refund Check	03/05/2020		3.90
Total for Check Number 10034:				0.00	3.90
10035	UB*03709	William Lyons Or RSI Communities LLC Refund Check	03/05/2020		3.90
Total for Check Number 10035:				0.00	3.90
10036	UB*03710	William Lyons Or RSI Communities LLC Refund Check	03/05/2020		67.67
Total for Check Number 10036:				0.00	67.67
10037	UB*03706	Danny Alcaarez Refund Check Refund Check Refund Check Refund Check	03/05/2020		38.35 22.41 27.51 82.62
Total for Check Number 10037:				0.00	170.89
10038	UB*03704	Vanessa & Michael Alvarez Refund Check	03/05/2020		34.75
Total for Check Number 10038:				0.00	34.75
10039	UB*03726	Mark Barnett Refund Check Refund Check Refund Check Refund Check	03/05/2020		18.83 39.29 56.71 13.51
Total for Check Number 10039:				0.00	128.34
10040	UB*03716	Ann Briley Refund Check	03/05/2020		50.24
Total for Check Number 10040:				0.00	50.24

Check No	Vendor No Invoice No	Vendor Name Description	Check Date Reference	Void Checks	Check Amount
10041	UB*03715	Cr&R Inc Refund Check Refund Check Refund Check Refund Check	03/05/2020		13.98 557.10 34.95 10.03
Total for Check Number 10041:				0.00	616.06
10042	UB*03643	Jennifer Garcia Refund Check	03/05/2020		22.86
Total for Check Number 10042:				0.00	22.86
10043	UB*03724	Kelli Green Refund Check	03/05/2020		68.85
Total for Check Number 10043:				0.00	68.85
10044	UB*03705	J Refugio Hernandez-Lomeli Refund Check Refund Check Refund Check Refund Check	03/05/2020		39.99 83.46 97.86 28.69
Total for Check Number 10044:				0.00	250.00
10045	UB*03719	Maria Jimenez Refund Check	03/05/2020		200.29
Total for Check Number 10045:				0.00	200.29
10046	UB*03725	Veronica Moran Refund Check	03/05/2020		244.00
Total for Check Number 10046:				0.00	244.00
10047	UB*03718	Ronald Muro Jr. Refund Check	03/05/2020		124.39
Total for Check Number 10047:				0.00	124.39
10048	UB*03711	Chase Anthony Norte Refund Check Refund Check Refund Check Refund Check	03/05/2020		20.82 10.34 7.09 66.16
Total for Check Number 10048:				0.00	104.41
10049	UB*03717	Daniela Onyisa Refund Check Refund Check Refund Check Refund Check	03/05/2020		9.17 23.82 12.77 26.67
Total for Check Number 10049:				0.00	72.43
10050	UB*03712	Nicole Pene Refund Check	03/05/2020		68.46
Total for Check Number 10050:				0.00	68.46

Check No	Vendor No Invoice No	Vendor Name Description	Check Date Reference	Void Checks	Check Amount
10051	UB*03720	Erica Perkins Refund Check	03/05/2020		192.80
Total for Check Number 10051:				0.00	192.80
10052	UB*03714	Joyce & Chistopher Pregmo Refund Check	03/05/2020		32.64
Total for Check Number 10052:				0.00	32.64
10053	UB*03707	Sonja Presley Refund Check	03/05/2020		250.00
Total for Check Number 10053:				0.00	250.00
10054	UB*03713	Pro - Craft Construction Refund Check Refund Check	03/05/2020		245.51 77.49
Total for Check Number 10054:				0.00	323.00
10055	UB*03728	Pro - Craft Construction Refund Check	03/05/2020		2,754.68
Total for Check Number 10055:				0.00	2,754.68
10056	UB*03722	Cianna Renna Refund Check Refund Check Refund Check Refund Check	03/05/2020		56.51 27.08 19.43 53.01
Total for Check Number 10056:				0.00	156.03
10057	UB*03721	Ligia Reyes Refund Check Refund Check Refund Check Refund Check	03/05/2020	VOID 713.37 511.76 232.64 1,783.42	
Total for Check Number 10057:				3,241.19	0.00
10058	UB*03723	Cindy Sandlin Refund Check Refund Check Refund Check Refund Check	03/05/2020		26.33 36.83 54.97 18.90
Total for Check Number 10058:				0.00	137.03
10059	UB*03702	Regina Uribe Refund Check	03/05/2020		0.53
Total for Check Number 10059:				0.00	0.53
10060	UB*03703	Wolverine World Wide Refund Check Refund Check Refund Check	03/05/2020		941.70 1,627.94 4,069.85
Total for Check Number 10060:				0.00	6,639.49

Check No	Vendor No Invoice No	Vendor Name Description	Check Date Reference	Void Checks	Check Amount
10061	UB*03727	Nancy Zeigler Lyons Refund Check	03/05/2020		83.42
Total for Check Number 10061:				0.00	83.42
Total for 3/5/2020:				3,241.19	128,390.41
ACH	10889 03092020	CDTFA 2019 Sales/Use Tax Payment	03/09/2020		958.00
Total for this ACH Check for Vendor 10889:				0.00	958.00
Total for 3/9/2020:				0.00	958.00
10062	10537 01112020	Joshua McCue Reimb - Cross Connection Specialist Exam - J McCue	03/12/2020		155.00
Total for Check Number 10062:				0.00	155.00
Total for 3/12/2020:				0.00	155.00
ACH	10030 2-03-937-4889 Feb 2-03-937-4889 Feb 2-03-937-4889 Feb 2-03-937-4889 Feb 2-03-937-4889 Feb 2-03-937-4889 Feb 2-03-937-4889 Feb 2-03-937-4889 Feb 2-03-937-4889 Feb	Southern California Edison Electricity 12/23 - 1/24/2020 - Wells Jan 2020 Electricity 1/24 - 2/24/2020 - 851 E 6th St - Feb 2020 Electricity 1/24 - 2/24/2020 - 815 E 12th Ave - Feb 2020 Electricity 11/24 - 2/24/2020 - 12303 Oak Glen Rd - Feb 2020 Electricity 1/24 - 2/24/2020 - Wells Feb 2020 Electricity 1/24 - 2/24/2020 - 13695 Oak Glen Rd - Feb 2020 Electricity 1/24 - 2/24/2020 - 560 Magnolia Ave - Feb 2020 Electricity 1/24 - 2/24/2020 - 13697 Oak Glen Rd - Feb 2020 Electricity 1/24 - 2/24/2020 - 9781 Avenida Miravilla - Feb 2020	03/16/2020		342.09 157.61 351.20 316.39 97,486.29 92.66 1,366.95 148.66 76.47
Total for this ACH Check for Vendor 10030:				0.00	100,338.32
ACH	10086 673878	American Family Life Assurance Company of Columbus AFLAC Employee Ins - Feb 2020	03/16/2020		1,024.26
Total for this ACH Check for Vendor 10086:				0.00	1,024.26
Total for 3/16/2020:				0.00	101,362.58
ACH	10288 02142020 02142020 02142020 02142020	CalPERS Health Fiscal Services Division Admin Fee for Active Emp Health Ins - March 2020 Active Employees Health Ins - March 2020 Retired Employees Health Ins - March 2020 Admin Fee for Retired Emp Health Ins - March 2020	03/18/2020		145.61 53,931.10 2,370.00 14.60
Total for this ACH Check for Vendor 10288:				0.00	56,461.31
Total for 3/18/2020:				0.00	56,461.31

Check No	Vendor No Invoice No	Vendor Name Description	Check Date Reference	Void Checks	Check Amount
ACH	10085	CalPERS Retirement System	03/19/2020		
	15946523	PR Batch 00004.03.2020 CalPERS ER Paid Classic			271.80
	15946523	PR Batch 00004.03.2020 CalPERS 7% EE Deduction			1,241.19
	15946523	PR Batch 00004.03.2020 CalPERS 8% EE Paid			2,397.13
	15946523	PR Batch 00004.03.2020 CalPERS 8% ER Paid			1,020.35
	15946523	PR Batch 00004.03.2020 CalPERS ER PEPRA			3,126.28
	15946523	PR Batch 00004.03.2020 CalPERS 7.5% EE PEPRA			3,114.66
	15946523	PR Batch 00004.03.2020 CalPERS ER Paid Classic			9,126.11
	15946523	PR Batch 00004.03.2020 CalPERS 1% ER Paid			177.30
Total for this ACH Check for Vendor 10085:				0.00	20,474.82
ACH	10087	EDD	03/19/2020		
	1-002-251-296	PR Batch 00004.03.2020 CA SDI			1,047.45
	1-002-251-296	PR Batch 00004.03.2020 State Income Tax			4,125.57
Total for this ACH Check for Vendor 10087:				0.00	5,173.02
ACH	10094	U.S. Treasury	03/19/2020		
	62315511	PR Batch 00004.03.2020 FICA Employer Portion			6,606.02
	62315511	PR Batch 00004.03.2020 Medicare Employer Portion			1,546.10
	62315511	PR Batch 00004.03.2020 Federal Income Tax			11,476.25
	62315511	PR Batch 00004.03.2020 FICA Employee Portion			6,606.02
	62315511	PR Batch 00004.03.2020 Medicare Employee Portion			1,546.10
Total for this ACH Check for Vendor 10094:				0.00	27,780.49
ACH	10141	Ca State Disbursement Unit	03/19/2020		
	8WVUZ5A6657	PR Batch 00004.03.2020 Garnishment			288.46
	8WVUZ5A6657	PR Batch 00004.03.2020 Garnishment			360.05
Total for this ACH Check for Vendor 10141:				0.00	648.51
ACH	10203	Voya Financial	03/19/2020		
	VB1450-PP06	PR Batch 00004.03.2020 Deferred Comp			475.00
Total for this ACH Check for Vendor 10203:				0.00	475.00
ACH	10264	CalPERs Supplemental Income Plans	03/19/2020		
	15987717	PR Batch 00004.03.2020 457 Loan Repayment			177.19
	15987717	PR Batch 00004.03.2020 CalPERS 457			640.00
	15987717	PR Batch 00004.03.2020 CalPERS 457 %			130.84
Total for this ACH Check for Vendor 10264:				0.00	948.03
ACH	10052	Home Depot Credit Services	03/19/2020		
	2292020	PVC Cement/Primer - General PVC Pipe Location			25.74
	2292020	Bushings/Tee/Mulch - Relocate Meter for Customer			41.60
	2292020	Bolts/Nuts/Lock washers/Post mast -Military Parking Sign			41.33
	2292020	Fast Setting Concrete - Fence - Cherry Ave/International Rd			84.85
	2292020	Compound - Noble Booster			17.62
	2292020	Deposit -Hydraulic Auger- Fence - Cherry Ave/International Rd			150.00
	2292020	Fast Setting Concrete - Fence - Cherry Ave/International Rd			113.14
	2292020	Tension Bands/Rail Ends/Bolts - Cherry Ave/International Rd			-404.81
	2292020	Fence - Cherry Ave/International Rd			1,481.40
	2292020	Primer/Gloss- Paint Air Vacs			69.01
	2292020	Light Fixture - Building/Well 3			75.39
	2292020	Top Rail/Tension Bands/Brace Banlds/Torch Blade - Fence Repairs			527.33
	2292020	Digital Level - Boring Machine			43.09
	2292020	Deposit -Hydraulic Auger- Fence Cherry Ave/International Rd			150.00
	2292020	Primer/Gloss- Paint Air Vacs			84.07
	2292020	7 Way Round Hardware - Fence Cherry Ave/International Rd			11.60
	2292020	Refund - Hydraulic Auger - Fence Cherry Ave/International Rd			-3.93
	2292020	Refund - Hydraulic Auger - Fence Cherry Ave/International Rd			-48.12
	2292020	Back Up Generator - SCADA System			968.67
	2292020	Ratchet for Fence Repairs - Cherry Ave/International Rd			40.88
	2292020	PVC Cutters - Unit 5			15.06
Total for this ACH Check for Vendor 10052:				0.00	3,483.92



Check No	Vendor No Invoice No	Vendor Name Description	Check Date Reference	Void Checks	Check Amount
ACH	10147 984409	Online Information Services, Inc 125 Credit Reports for Feb 2020	03/19/2020		367.50
Total for this ACH Check for Vendor 10147:				0.00	367.50
10063	10099 22999	A & A Fence Co. Inc Repair Shop Gates, Post, Hinges, 2 Gates	03/19/2020		1,265.42
Total for Check Number 10063:				0.00	1,265.42
10064	10792 04012020	A-1 Financial Services April 2020 Rent - 851 E 6th St - Eng Office	03/19/2020		2,025.00
Total for Check Number 10064:				0.00	2,025.00
10065	10144 LYUM1431582 LYUM1435453 LYUM1439335 LYUM1447191 LYUM1447193	Alsco Inc Cleaning of 3 Office Mats 560 Magnolia Jan 2020 Cleaning of 3 Office Mats 560 Magnolia Jan 2020 Cleaning of Mats & Shop Towels 12th/Palm Feb 2020 Cleaning of Mats & Shop Towels 12th/Palm March 2020 Cleaning of 3 Office Mats 560 Magnolia March 2020	03/19/2020		18.29 20.95 17.35 33.65 20.95
Total for Check Number 10065:				0.00	111.19
10066	10855 S1124559.001	Badger Meter, Inc (97) 1" Meters w/Wire - Inventory	03/19/2020		24,770.65
Total for Check Number 10066:				0.00	24,770.65
10067	10019 0099767	C R & R Incorporated Monthly Charges 3 YD Commercial Bin - March 2020	03/19/2020		542.94
Total for Check Number 10067:				0.00	542.94
10068	10249 XCC2428 XCC2428	CDW Government LLC (4) Replacement Computers - Server Replacement Project 12th/Palm (8) Monitors and Rec Fees - Server Replacement Project 12th/Palm	03/19/2020		4,857.93 2,540.06
Total for Check Number 10068:				0.00	7,397.99
10069	10783 03122020	Cherry Valley Association Community Outreach - 102nd Annual Cherry Festival	03/19/2020		250.00
Total for Check Number 10069:				0.00	250.00
10070	10016 261701 Jan-Feb	City of Beaumont Bi-Monthly Sewer Charges 1/1 - 3/01/2020 Jan-Feb 2020	03/19/2020		54.08
Total for Check Number 10070:				0.00	54.08
10071	10112 792558 792558	Cla-Val Labor - Rebuilt Main Valves/Pilot - Oak Glen Rd PRV Station Seat/Stem - Oak Glen Rd PRV Station	03/19/2020		1,560.52 1,858.54
Total for Check Number 10071:				0.00	3,419.06
10072	10719 03162020	HR Dynamics & Performance Management, Inc General Consulting/Coaching/Mentoring - 2/16 - 3/15/2020 - HR	03/19/2020		2,250.00
Total for Check Number 10072:				0.00	2,250.00

Check No	Vendor No Invoice No	Vendor Name Description	Check Date Reference	Void Checks	Check Amount
10073	10398	Infosend, Inc	03/19/2020		
	167968	Feb 2020 Postage Charges for Utility Billing			4,600.69
	167968	Feb 2020 Supply Charges for Utility Billing			528.43
	167968	Feb 2020 Billing Charges for Utility Billing			1,200.80
Total for Check Number 10073:				0.00	6,329.92
10074	10273	Inland Water Works Supply Co.	03/19/2020		
	S1031895.004	(34) Security Seals for Transmitters			7.18
	S1032668.004	(20) 1015 Meter Boxes - Inventory			42.23
	S1032668.004	(20) 1015 Meter Lids - Inventory			21.12
	S1032668.005	(17) 1320 Meter Lids - Inventory			179.51
	S1032668.005	(17) 1320 Meter Boxes - Inventory			753.94
	S1033079.001	(300ft) 3 Rolls 100' 1" Copper - Inventory			1,213.92
	S1033079.001	(480ft) 8 Rolls of 60' 1" Copper - Inventory			1,942.27
Total for Check Number 10074:				0.00	4,160.17
10075	10800	Kyle Irwin	03/19/2020		
	1063	Labor - Replace Flag Pole - 560 Magnolia			170.00
	1063	Material - 560 Magnolia			555.00
	1063	Labor - Fabricate Covers for Light - 560 Magnolia			300.00
Total for Check Number 10075:				0.00	1,025.00
10076	10224	Legal Shield	03/19/2020		
	0101129 March	Monthly Prepaid Legal for Employees March 2020			214.30
Total for Check Number 10076:				0.00	214.30
10077	10281	Luther's Truck and Equipment	03/19/2020		
	44019	Labor - Replace Mud Flap - Kenworth Dump Truck			55.00
	44019	Mud Flap Hanger - Kenworth Dump Truck			95.22
Total for Check Number 10077:				0.00	150.22
10078	10026	McCrometer Inc	03/19/2020		
	534715RI	Replace Meter - Well 4A			2,844.90
Total for Check Number 10078:				0.00	2,844.90
10079	10350	NAPA Auto Parts	03/19/2020		
	114736	Socket - Unit 32			2.68
	114736	Battery - Unit 32			151.84
	116292	Trailer Hitch Adapter - Unit 10			21.54
Total for Check Number 10079:				0.00	176.06
10080	10045	Pacific Alarm Service Inc	03/19/2020		
	R153959	Alarm Equip/Rent/Service/Monitor 815 E 12th St			76.00
Total for Check Number 10080:				0.00	76.00
10081	10632	Quinn Company	03/19/2020		
	WOG00007174	Annual PM 2 Service - Well 21			482.37
	WOG00007174	Labor Annual PM 2 Service - Well 21			727.00
	WOG00007174	Labor to Remove and Replace All Batteries - Well 21			112.50
	WOG00007174	Remove and Replace All Batteries - Well 21			623.01
Total for Check Number 10081:				0.00	1,944.88

Check No	Vendor No Invoice No	Vendor Name Description	Check Date Reference	Void Checks	Check Amount
10082	10056 P6082235 P6312135	RDO Equipment Co. Trust# 80-5800 Replace Seat on Green Tractor Bearings/Hangers/Axles/Disk - JD Backhoe	03/19/2020		0.26 2,787.98
Total for Check Number 10082:				0.00	2,788.24
10083	10171 01312020	Riverside Assessor - County Recorder Jan 2020 Lien Fees	03/19/2020		20.00
Total for Check Number 10083:				0.00	20.00
10084	10317 636003 636003 649753	Robertson's Ready Mix 25 Tons of Base - Magnolia Capital Replacement Job 25 Tons of Sand - Magnolia Capital Replacement Job Sand and Base for Beaumont Ave Project	03/19/2020		344.71 377.39 1,446.79
Total for Check Number 10084:				0.00	2,168.89
10085	10290 20-00212	San Gorgonio Pass Water Agency 2,064 AF @ \$399 for Feb 2020	03/19/2020		823,536.00
Total for Check Number 10085:				0.00	823,536.00
10086	10031 3441760389 3441760389 3442431548	Staples Business Advantage (2) Pens - Eng Office Kleenex/Paper Towels/Clorox Wipes - 560 Magnolia Black Toner - 560 Magnolia	03/19/2020		30.88 165.44 223.03
Total for Check Number 10086:				0.00	419.35
10087	10265 8334781-001 8334781-002	Sunstate Equipment Co., LLC Rent Arrow Board for Beaumont Ave Project Rent Arrow Board for Beaumont Ave Project	03/19/2020		1,070.78 161.44
Total for Check Number 10087:				0.00	1,232.22
10088	10881 BCVWD-2019-001	T.R. Holliman and Associates, Inc Prof Consulting - Jan 2020 - Recycled Water Implementation Rd	03/19/2020		7,500.00
Total for Check Number 10088:				0.00	7,500.00
10089	10063 1051979	The Record Gazette Inviting Bids - 9th/11th Pipeline Replacement	03/19/2020		960.00
Total for Check Number 10089:				0.00	960.00
10090	10778 5351 5351 5351 5351 5351 5351 5351 5351 5351 5351 5351	Urban Habitat Well Site 25 2750 Pressure Zone Reservoir (Cherry Tanks) Well Site 3 Well Site 22 2650 Pressure Zone Reservoir (Hannon Tank) Well Site 2 BCVWD Business Office 2850 Pressure Zone Reservoir (Vineland Tanks) Well Site 24 Well Site 29 Well Site 16	03/19/2020		90.00 840.00 330.00 420.00 780.00 270.00 90.00 420.00 240.00 180.00 300.00
Total for Check Number 10090:				0.00	3,960.00

Check No	Vendor No Invoice No	Vendor Name Description	Check Date Reference	Void Checks	Check Amount
10091	10116 9849336188 9849336188	Verizon Wireless Services LLC Cell Phone Charges for Feb 2020 iPad Charges for Feb 2020	03/19/2020		224.65 120.03
Total for Check Number 10091:				0.00	344.68
10092	10421 72522647	Vulcan Materials Company (24.59) Temp Asphalt for Beaumont Ave Street Replacement	03/19/2020		2,590.52
Total for Check Number 10092:				0.00	2,590.52
10093	10293 175426	Western Dental Services Inc Western Dental Premiums March 2020	03/19/2020		86.14
Total for Check Number 10093:				0.00	86.14
Total for 3/19/2020:				0.00	963,965.11
ACH	10087 0-884-024-352 0-884-024-352	EDD PR Batch 00005.03.2020 CA SDI PR Batch 00005.03.2020 State Income Tax	03/25/2020		21.11 283.40
Total for this ACH Check for Vendor 10087:				0.00	304.51
ACH	10094 95998177 95998177 95998177 95998177 95998177	U.S. Treasury PR Batch 00005.03.2020 Medicare Employer Portion PR Batch 00005.03.2020 Federal Income Tax PR Batch 00005.03.2020 Medicare Employee Portion PR Batch 00005.03.2020 FICA Employer Portion PR Batch 00005.03.2020 FICA Employee Portion	03/25/2020		72.18 660.70 72.18 308.61 308.61
Total for this ACH Check for Vendor 10094:				0.00	1,422.28
ACH	10781 10016 10034 10052 10098 10173 10303 10319 10393	Umpqua Bank City of Beaumont Police Report for Damage Claims Viele Ave US Postal Service 400 Postage Stamps Home Depot Credit Services 150CT 13-Gallon Trashbags for 560 Magnolia Ave County of Riverside Dept of Environmental Health Enviromental Fee California Society of Municipal Finance Officers CSMFO IE Chapter Meeting (Canceled) - Finance Staff - Pending Credit Annual CSMFO Membership 2020 - W Clayton Annual CSMFO Membership 2020 - Y Rodriguez Annual CSMFO Membership 2020 - S Molina Annual CSMFO Membership 2020 - L Lopez Grainger Inc Safety Knee Boots - V Litka (2) Single Function Time Relays - Well 21 and Spare (2) Redhat 120VAC Brass Solenoid Valve-Well 21 and Spare ACWA Joint Powers Insurance Authority Human Resources Training w/ACWA JPIA - S Foley ACWA JPIA Training(Postponed) - A Couch ACWA JPIA Training(Postponed) - K Dahlstrom Alaska Airlines Conference Return Flight 05/13/2020 (Canceled) - Pending Credit	03/25/2020		1.75 220.00 15.05 52.50 150.00 110.00 110.00 75.00 75.00 60.05 209.55 729.60 190.00 95.00 95.00 273.60

Check No	Vendor No Invoice No	Vendor Name Description	Check Date Reference	Void Checks	Check Amount
	10420	Amazon.com (2) TV's for GM Office and Conference Room (2) Mount for TV's for GM Office and Conference Room			1,372.13 203.46
	10424	Top-Line Industrial Supply, LLC (10) Flat Washers for Boring Machine			7.33
	10526	Verizon Monthly Phone Service 02/01-02/28/2020			979.47
	10546	Frontier Communications 02/10-03/09/2020 Feb FIOS/FAX 12th/Palm 01/25-02/24/2020 Feb FIOS/FAX 841 E 6th St 01/25-02/24/2020 Feb FIOS/FAX 560 Magnolia Ave			316.12 99.65 290.00
	10572	Southwest Airlines Flight for Springbrook 05/11/2020 (Canceled) - Pending Credit			391.92
	10623	WP Engine Web Host for BCVWD Website Feb 2020			30.00
	10692	MMSoft Design Network Monitoring Software Feb 2020			206.18
	10761	BLS*Spamtitan Email Filtering - Districtwide Feb 2020 Monthly Web Filter License Feb 2020			47.94 71.88
	10766	Sam's Club Membership Renewal - BCVWD			100.00
	10784	Autodesk, Inc Auto CAD Software - 851 E 6th St Feb 2020			710.00
	10790	Microsoft Monthly Microsoft Office License - Feb 2020 Monthly Microsoft Exchange - Feb 2020			500.00 264.00
	10824	U-Line (35) 48x40 Pallets for Field Inventory			1,110.80
	10846	Art To Frames Frame for Board Room			33.29
	10848	DLR-Anaheim Conference Hotel 01/28-01/31/2020-S Molina & L Lopez Conference Hotel 01/28-01/31/2020-Y Rodriguez Conference Hotel 01/29-01/31/2020-S Delgadillo Conference Hotel 01/29-01/31/2020-W Clayton			660.96 615.96 315.48 315.48
	10882	TT Technologies (4) Grundo Oil All Season for Boring Machine 50" Air Hose w/Couplings for Boring Machine 3" to 5" Starting Cradle for Boring Machine			210.72 371.41 1,791.25
	10883	Wantate.com Fraud Transaction - Feb 2020 - Pending Credit			40.79
	10884	UCB-CPER HR Pocket Guides/Relations/FMLA/Brown Act/WComp/Investigations			222.99
	10885	Mediaion.com Fraud Transaction - Feb 2020 - Pending Credit			39.99
	10886	Test Equipment Depot Exstick II pH/Conductivity/Temp Meter - Rec Water Conversion			320.99
	10887	Purple Heart Store Use Tax-Purple Heart Reserved Parking Sign for 560 Magnolia Ave Purple Heart Reserved Parking Sign for 560 Magnolia Ave			-3.48 54.43
	10888	Tortilla Joes Conference Dinner Expense 01/31/2020 - Y Rodriguez			33.62
Total for this ACH Check for Vendor 10781:				0.00	14,186.86
Total for 3/25/2020:				0.00	15,913.65

Check No	Vendor No Invoice No	Vendor Name Description	Check Date Reference	Void Checks	Check Amount
ACH	10138 HW201 Mar 2020	ARCO Business Solutions ARCO Fuel Charges 02/12-03/12/2020	03/26/2020		5,373.68
Total for this ACH Check for Vendor 10138:				0.00	5,373.68
10094	10000 227738 227739 227740	A C Propane Co Propane Refill Feb 2020 - 13697 Oak Glen Rd Propane Refill Feb 2020 - 9781 Avenida Miravilla Propane Refill Feb 2020 - 13695 Oak Glen Rd	03/26/2020		351.07 471.83 229.62
Total for Check Number 10094:				0.00	1,052.52
10095	10001 47992 47992 47992 47992 47992 47992 47992 47992 47992 47992	Action True Value Hardware Drill Bits - Unit 5 Bolts/Washers - 12th/Palm Pliers/Hog Rings - All District Fences Caution Tape/Air Fittings/Paint Marker - Unit 17 Carburation Cleaner/Brush Set - 12th/Palm 5ft Chain - Lower Canyon Gate Tie Down Rope - Tarps Level - Unit 4 (3) Spray Paint - Painting Air Vacs	03/26/2020		22.51 8.15 26.90 27.96 11.62 25.81 18.31 10.76 17.09
Total for Check Number 10095:				0.00	169.11
10096	10272 CB00642 CB00644 CB00956 CB01178 CB01179 CB01873 CB01875	Babcock Laboratories Inc (15) Coliforms Lab Samples (2) Coliforms Wells (1) Coliforms Wells (1) Coliforms Wells (15) Coliforms Lab Samples (3) Coliforms Wells (15) Coliforms Lab Samples	03/26/2020		630.00 84.00 42.00 42.00 630.00 126.00 630.00
Total for Check Number 10096:				0.00	2,184.00
10097	10271 1-Feb	Beaumont Ace Home Center Rope - Unit 4 (2) Hill Rings - Fence Cherry Ave/International Rd Fence Pliers - Unit 5 Elbows/Valve - Installing Earthtec Well 16 Outlet/Connector/Box Cover - Well 16 Building PVC Pipe/Adapter/Coupling - Btw 9th & 11th Connector/Nipple/Reducer - Well 16 Pressure Gauge/Bushing/Coupling - Chlorinator Well 25 Double Loop Chain - Recharge Facility - Phase 1 Muriatic Acid - Chlorine Well 25 Pulley - Swamp Cooler Well 25 PVC Pipes - House Connections Tape/Shovels/Lubricant - Unit 4 Wire Brush/Scraper - Unit 35 Chip Brush - Air Vacs/Lids/FH Rolling Tool Cart - Bore Machine Spray Paint - District Wide Wire Brush - Unit 32 Shackles/Nuts/Bolts - Disking Attachments Nipple/Adapter/Coupling - Magnolia Ave Primer/Chip Brushes - Air Vacs/Blows Off Tape Measure/Box of Gloves - Unit 42	03/26/2020		82.06 9.24 12.39 23.65 33.24 109.09 22.38 24.19 9.67 8.61 15.07 9.68 110.71 13.77 9.63 59.25 27.97 6.78 31.03 27.14 70.32 28.54



Check No	Vendor No Invoice No	Vendor Name Description	Check Date Reference	Void Checks	Check Amount
	1-Feb	Glass Cleaner/Inspection Mirror - Unit 5			17.76
	1-Feb	Inspection Mirrors - Unit 13			4.85
	1-Feb	Towels/Rapid Concrete - Cherry Ave/International Rd			120.82
	1-Feb	Roundup - Edgar Canyon			199.33
	1-Feb	Paint Tray/Covers - Painting Air Vacs			44.55
	1-Feb	Muriatic Acid - Chlorine Well 21			8.61
	1-Feb	Blade Set/Level - Unit 4			38.23
	1-Feb	(3) 9" Gauge- Refencing Cherry Field			66.23
	1-Feb	Clamps/Adapter/Valve - Installing Earthtec Well 16			26.44
	1-Feb	Valves/Nipples - Well 3			71.93
	1-Feb	Hill Rings/Rail Ends - Fence Cherry Ave			7.19
	1-Feb	Chip Brush for KHov Air Vacs			14.57
	1-Feb	Hardware - Parking Sign - 560 Magnolia			0.78
	1-Feb	Blades/Wax/Freshener - Unit 32			20.22
	1-Feb	Gate Hinge - Recharge Facility - Phase 1			2.36
	1-Feb	Elbows - Magnolia Ave/9th			5.09
	1-Feb	Brush - 12th and Palm			5.92
	1-Feb	PVC Union - Chlorine Line Well 25			3.54
	1-Feb	PVC Pipe/Adapter - Service Line Magnolia Ave			12.46
	1-Feb	Street Ell - Samples Well 18			8.39
	1-Feb	(2) Outlet - Well 3 Building			46.31
	1-Feb	Trailer Jack - Compressor			53.86
Total for Check Number 10097:				0.00	1,523.85
10098	10223 225473	Richards, Watson & Gershon Legal Services Jan Board Approval 03/11/2020	03/26/2020		3,295.00
Total for Check Number 10098:				0.00	3,295.00
10099	10689 180737	Safety Compliance Company Back Safety Mtg 02/26/2020	03/26/2020		250.00
Total for Check Number 10099:				0.00	250.00
10100	10132 3593443 3593443 3595435	South Coast AQMD Fac ID: 120877/F42560 Operating Fee - Generator Diesel Fac ID: 120877/G1195 Operating Fee - Generator Diesel Fac ID: 120877 Flat Fee for Prior Year Emissions	03/26/2020		421.02 421.02 136.40
Total for Check Number 10100:				0.00	978.44
10101	10063 1054143 1054151	The Record Gazette Rate Increase Public Hearing Notice Bid Announcement for NCR Fencing	03/26/2020		1,065.00 900.00
Total for Check Number 10101:				0.00	1,965.00
10102	UB*03738	Johnny Duran & Conrad Delgadillo & Nicole Regnosa Refund Check	03/26/2020		165.97
Total for Check Number 10102:				0.00	165.97
10103	UB*03733	Desiree Alvarez Refund Check Refund Check Refund Check Refund Check	03/26/2020		14.11 201.41 10.12 29.43
Total for Check Number 10103:				0.00	255.07

Check No	Vendor No Invoice No	Vendor Name Description	Check Date Reference	Void Checks	Check Amount
10104	UB*03740	Casmonasitara Byrdsong Refund Check	03/26/2020		144.72
Total for Check Number 10104:				0.00	144.72
10105	UB*03732	CDN Premier Realty Refund Check	03/26/2020		14.37
Total for Check Number 10105:				0.00	14.37
10106	UB*03729	Hometown Prop. Mang. Charles B. Howard C/O Refund Check	03/26/2020		151.53
Total for Check Number 10106:				0.00	151.53
10107	UB*03734	Mamie Cornett Refund Check	03/26/2020		6.88
Total for Check Number 10107:				0.00	6.88
10108	UB*03736	Amancio Gonzalez Refund Check	03/26/2020		0.29
Total for Check Number 10108:				0.00	0.29
10109	UB*03739	Mario Gordillo Refund Check Refund Check Refund Check Refund Check	03/26/2020		127.78 29.26 19.26 11.22
Total for Check Number 10109:				0.00	187.52
10110	UB*03731	Marlin Monge Refund Check	03/26/2020		190.43
Total for Check Number 10110:				0.00	190.43
10111	UB*03730	Yolanda Rivera Refund Check	03/26/2020		180.66
Total for Check Number 10111:				0.00	180.66
10112	UB*03735	Kevin & Stacey Robinson Refund Check	03/26/2020		127.62
Total for Check Number 10112:				0.00	127.62
10113	UB*03742	Brittany Smith Refund Check Refund Check Refund Check Refund Check	03/26/2020		47.55 7.25 11.89 19.21
Total for Check Number 10113:				0.00	85.90

Check No	Vendor No Invoice No	Vendor Name Description	Check Date Reference	Void Checks	Check Amount
10114	UB*03737	Kimberly Strutton	03/26/2020		
		Refund Check			28.74
		Refund Check			140.67
		Refund Check			20.62
		Refund Check			59.97
Total for Check Number 10114:				0.00	250.00
10115	UB*03741	Harry Voland	03/26/2020		
		Refund Check			80.53
Total for Check Number 10115:				0.00	80.53
Total for 3/26/2020:				0.00	18,633.09
Report Total (174 checks):				3,241.19	1,285,839.15



**Beaumont-Cherry Valley Water District  
Board of Directors Meeting  
April 8, 2020**

Item 2d

STAFF REPORT

**TO:** Board of Directors  
**FROM:** Dan Jagers, General Manager  
**SUBJECT:** Approval of Pending Invoices

---

**Staff Recommendation**

Approve the pending invoices totaling \$8,861.28.

**Background**

Staff has reviewed the pending invoice and found the services rendered were acceptable to the District.

**Fiscal Impact**

There is a \$8,861.28 impact to the District which will be paid from the 2020 budget.

**Attachment(s)**

- Richards Watson Gershon Invoice # 225879



T 213.626.8484  
F 213.626.0078  
Fed. I.D. No. 95-3292015

350 South Grand Avenue  
37th Floor  
Los Angeles, CA 90071

**CONFIDENTIAL**  
This material is subject to the attorney-client privilege and/or attorney work product protection, or otherwise is privileged or confidential. Do not disclose the contents hereof. Do not file with publicly-accessible records.

DAN JAGGERS, GENERAL MANAGER  
Beaumont- Cherry Valley Water District  
560 Magnolia Avenue  
Beaumont, Ca 92223-2258

March 13, 2020  
Invoice # 225879

Re: [REDACTED] GENERAL COUNSEL SERVICES

*For professional services rendered through February 29, 2020:*

---

Current Legal Fees .....	\$8,607.50
Current Client Costs Advanced .....	<u>\$253.78</u>
<b>TOTAL CURRENT FEES AND COSTS .....</b>	<b><u>\$8,861.28</u></b>
Balance Due From Previous Statement.....	\$3,295.00
<b>TOTAL BALANCE DUE FOR THIS MATTER .....</b>	<b><u>\$12,156.28</u></b>

**TERMS: PAYMENT DUE UPON RECEIPT**

**PLEASE RETURN THIS PAGE WITH YOUR REMITTANCE TO**

**RICHARDS, WATSON & GERSHON**  
**350 South Grand Avenue, 37th Floor**  
**Los Angeles, CA 90071**

**RICHARDS WATSON GERSHON**



**BEAUMONT-CHERRY VALLEY WATER DISTRICT  
MINUTES OF REGULAR MEETING  
OF THE BOARD OF DIRECTORS  
560 Magnolia Avenue, Beaumont, CA 92223  
Wednesday, March 11, 2020 at 6:00 p.m.**

---

**Call to Order:** *President Covington began the meeting at 6:03 p.m.*

**Pledge of Allegiance:** Director Ramirez

*Director Ramirez led the pledge.*

**Invocation:** Director Slawson

*Invocation was given by Director Slawson.*

**Roll Call:**

Directors present:	Covington, Ramirez, Slawson, Williams
Directors absent:	Hoffman
Staff present:	General Manager Dan Jiggers, Director of Finance and Administration Yolanda Rodriguez, Senior Engineer Mark Swanson, Assistant Director of Operations James Bean, Senior Finance and Administrative Analyst William Clayton, Administrative Assistant Erica Gonzales, Senior Accountant Sylvia Molina, Accountant III Lorena Lopez, Accounting Technician Sally Hernandez

Members of the public who registered attendance: Fran Flanders.

**Public Comment:** None.

**1. Adjustments to the Agenda:** None.

**2. Consent Calendar:**

*The following Consent Calendar items were approved with one motion:*

- a. January 2020 Budget Variance Report
- b. January 2020 Cash/Investment Balance Report
- c. February 2020 Check Register
- d. February 2020 Invoices Pending Approval
- e. Minutes of the Regular Meeting of February 12, 2020
- f. Minutes of the Regular Meeting of February 27, 2020

//  
//  
//

MOVED: Williams	SECONDED: Slawson	APPROVED 4-0
AYES:	Covington, Ramirez, Slawson, Williams	
NOES:	None.	
ABSTAIN:	None.	
ABSENT:	Hoffman	

**3. Acknowledge receipt of the Certificate of Achievement for Excellence in Financial Reporting from the Government Finance Officers Association for BCVWD’s 2018 Comprehensive Annual Financial Report**

Director of Finance and Administration Yolanda Rodriguez explained the certification and noted this is the second year the District has received the award.

President Covington noted this is a prestigious award and noted the District is being truly recognized for its financial experience and professionalism.

Director Williams commended staff for efforts to keep everything straight and above board. She said it is a testament to the level of professionalism and talent of the team. Director Ramirez and Director Slawson congratulated the staff.

General Manager Jaggars noted that the staff weathered a very busy and challenging 2019 year with effort above and beyond.

RECESS: President Covington called a recess at 6:10 p.m.

RECONVENE: The meeting was reconvened at 6:14 p.m.

**4. Authorization of General Manager to enter into a Contract in an amount not to exceed \$27,792.00 for Reservoir Cleaning, Inspection and Minor Repair with Advanced Diving Services, Inc.**

Assistant Director of Operations James Bean advised that each year, three to five reservoirs are scheduled for inspection and cleaning. A diving company goes in and cleans sediment, and inspects the coating, welds, seams, ladders and more, he explained. Quotes were solicited for this year’s work and three companies responded, Bean said, with Advanced Diving Services being the lowest responsive qualified bidder.

President Covington asked which reservoirs were to be cleaned; Mr. Bean answered the Request for Quotation included Upper and Lower Edgar, Highland Springs and the 2800 non-potable reservoirs.

In response to Director Ramirez, Mr. Bean explained the reservoirs are filled as close as possible to overflow so the divers can go through the entire column and get a good look and video. He explained the process for the divers including disinfection of their dry suits and equipment, and stated the reservoir remains in full service during the cleaning. Minor repairs such as chipping in the coating can be made during the dive.

President Covington asked about normal monthly maintenance, and Mr. Bean noted inspections are done for the condition of the screening equipment, ladders, sediment content and more.



The Board authorized the General Manager to enter into a contract with Advanced Diving Services, Inc. to provide reservoir cleaning, inspection and minor repair of three (3) domestic drinking water reservoirs and one (1) non-potable storage reservoir currently owned by the Beaumont-Cherry Valley Water District by the following vote:

MOVED: Slawson	SECONDED: Ramirez	APPROVED 4-0
AYES:	Covington, Ramirez, Slawson, Williams	
NOES:	None.	
ABSTAIN:	None.	
ABSENT:	Hoffman	

**5. 2019 - 2020 Noble Creek Recharge Facility Phase I and II Pond Maintenance Costs**

General Manager Jagers explained this annual activity. Extra work needed exceeded the GM's purchasing limit by a small amount. This is a time and materials-based contract awarded to the lowest and best available bid. Historically this has been under budget, but materials were added and this is in front of the Board in order to be transparent, Jagers advised.

Jagers detailed the work and equipment involved. President Covington asked about Board action necessary. GM Jagers requested Board approval of the \$26,086 to be expended.

Director Williams pointed out this is a difference of only \$1,086 over the GM's spending authorization. GM Jagers explained the timing of the projects which began in December. Director Ramirez asked about the buildup of sediment. Jagers noted the conditions are affected by weather and the water quality of the State Water Project water and explained some issues.

President Covington expressed concern about approval of the total of both the 2019 and 2020 expenses due to potential confusion. Ms. Rodriguez indicated that normally, the initial expense would be ratified in 2018 with the 2019 budget. This Board approval would be for the excess amount for 2020, she said; legal counsel concurred.

*The Board approved expenses of \$26,086 in 2020 line item 01-40-470-540072, which was included in the approved 2020 operating budget by the following vote:*

MOVED: Williams	SECONDED: Slawson	APPROVED 4-0
AYES:	Covington, Ramirez, Slawson, Williams	
NOES:	None.	
ABSTAIN:	None.	
ABSENT:	Hoffman	

**6. Beaumont Master Drainage Plan Line 16 Facilities Design, Funding Requirements and Timeline**

Mr. Jagers reminded the Board of previous discussions and advised that the project has a higher cost now that new 60 percent drawings are available from the design consultant. The original 60 percent design had an estimated engineer's cost



of \$8.257 million which was unacceptable to the Riverside County Flood Control and Water Conservation District (RCFC&WCD) and to BCVWD.

BCVWD identified some opportunities for value engineering and the consultant was able to reduce the cost to \$6,665 million, Jagers explained. This is the point where BCVWD must approve the 60 percent design drawings and has authorized a \$50,000 contribution, and work is moving forward.

There is also discussion regarding the Memorandum of Agreement (MOA), Jagers continued. He said he asked RCFC&WCD if funding was available for a 60/40 cost split, and they indicated they could provide funding for a 50/50 split, as some of the cost increase is on the BCVWD facility side. Mr. Jagers detailed staff's plan analysis and said he believes the design addresses all the activities but there is cost creep.

GM Jagers reminded the Board that capacity charges (facilities fees) are collected for local water resources. A more robust cost estimate has been requested for the Board to take a more in-depth look, Jagers noted.

Mr. Jagers said he plans to approve the 60 percent drawings tomorrow to allow completion and bring back this item to the Board for further discussion on cost realities and to obtain the Board's thoughts, plus a cost-sharing agreement.

This project is included in the District's master plan and is also part of the current capacity charges study, Jagers advised. Timelines are getting tighter, he explained, as most engineers from RCFC&WCD were tied up for a year working on repair of facilities damaged in the Cleveland National Forest fire.

Director Ramirez asked if the cost increase was due to the full scope of the plan not being considered. Mr. Jagers answered that much of the extra cost is on the RCFC&WCD side. The preliminary design estimate was low, he said, and there have been three or four years of construction cost increases. Mr. Swanson added detail regarding engineering costs as determined by RCFC&WCD. The numbers were not a mistake; Swanson continued in response, estimates are based on a general rule of thumb and when examined in more detail the costs change.

Mr. Jagers added that this is a non-traditional facility and there is a street grade of 3 percent resulting in the actual facilities required being significantly more than anticipated in the preliminary design.

Ramirez asked for a simplification of the answer regarding cost increases. Mr. Jagers explained the engineer's estimate is based on general information and was done quickly for inclusion in a grant application. It seemed reasonable for the facility at the time, Jagers said.

President Covington asked for this item to be brought back at the Engineering Workshop and for plans to be on-screen. He requested information that would allow the Board to support a project that has doubled in cost.

Mr. Jagers indicated there would be another submittal, but staff would approve the 60 percent design in order to keep the project moving and not further compress the schedule. This commits only to design completion, he advised, not construction.

President Covington asked also for an update on the agreement that is not yet signed. He directed staff to bring an executed agreement back from RCFC&WCD for Board signature. Mr. Jagers noted there is a cost-sharing agreement. Covington opined that was a second agreement and Ramirez added that the Board should reconsider the percent of participation.

Mr. Jagers acknowledged and said the project and agreement will be brought to the Workshop. This is now a \$7 million project without any kind of agreement, Covington noted. Mr. Swanson noted that District staff believes they have responded to all questions of RCFC&WCD. Jagers added that RCFC&WCD has indicated they want to get it done. President Covington suggested that Jason Uhley (General Manager and Chief Engineer at RCFC&WCD) might come before the Board to explain. He also reminded that there will be an operations and maintenance agreement to be signed in addition.

Director Ramirez suggested requesting more financial participation from RCFC&WCD. Jagers said he has already made the request for a 60/40 split. Ramirez acknowledged staff's effort and suggested the Board offer more support for the GM to push for more financial commitment. Mr. Jagers said he would begin the query, and President Covington and Director Ramirez indicated support.

## **7. Status Update regarding Well 21 and Well 29 Performance**

Mr. Jagers advised that the District is being proactive on its big pumping wells.

Mr. Bean reported that worsening vibration issues were noted at Well 21 and there may be issues with that pumping unit. Staff is putting together an RFP to pull and inspect the equipment and with Well 21 being down, staff wanted to assure redundancy in the system and began looking at Well 29.

Director Ramirez asked the age of the Well 21 motor and Mr. Jagers noted it was replaced last year, but the noise is not coming from the motor. Bean explained the noise appears to be subsurface.

At about the same time, Bean continued, a different noise was noticed on the Well 29 motor. The motor vendor came out and recommended that if the motor was going to be pushed, the bearings should be inspected, Bean reported. In response to Director Ramirez, Bean noted that the Well 29 issue is on the electric motor itself and if the District will be relying on that well through the summertime to make up for the loss of production from Well 21, staff wanted to assure the motor is ready to go, and it is a quick turnaround.

Mr. Jagers indicated that Well 29 was a pump that was rehabilitated two years ago under an emergency declaration. Due to the bearing load, the well has a 10-year, 10 percent failure rate, so staff is very proactive and protective of the large production wells due to the opportunity for bearing failure, he explained.

Mr. Bean added that Well 21 has been pulled only once since 1999 to replace the pumping unit. President Covington noted this is being addressed in March rather than the middle of summer.

## 8. Reports For Discussion

### a. Ad Hoc Committees:

Ad Hoc Communications Committee: Director Williams reported on the meeting with CV Strategies with Director Hoffman attending as the alternate Committee member. CV Strategies provided data on the reach and engagement of posts. Two of the largest were the informational community meeting about the public hearing, and the public hearing, she said. The newsletter was previewed, and discussion continued on other items moving forward, she said, including getting more information out about the capacity charges (facilities fees) study and video development. Also discussed was each director having a page on the website for specific division news if the need arises for that.

### b. General Manager

Mr. Jagers reported that the District is working on coronavirus response. The HR department is preparing, Jagers continued, and said discussions are ongoing about maintaining operations and limiting public contact. Trends in the industry are being monitored such as public access to the office and staff will come back to the Board with further news and strategies.

A public hearing on Chromium 6 is coming up in April and Mr. Jagers said he reached out to Steve Bigley who serves on the related Association of California Water Agencies (ACWA) committee. BCVWD has three wells that will be affected by Chromium 6 if the state goes back to the same level of concentration which may be problematic for the District. The state seems willing to look at stannous chloride as a potential solution on a case-by-case basis, Jagers said, but it may not make the list of best available technologies. There may be an opportunity for BCVWD to partner with Coachella Valley Water District (CVWD) to run a demonstration test in its non-potable system at one of the high-chromium wells, Jagers said.

President Covington asked if the American Water Works Association anticipated that the state would try to attain the previous mcl as set. Mr. Jagers noted that white papers prepared by the regional board indicated it was unknown how to do an economic analysis of the issue. Some of the discussion has been on how to do the economic study and perhaps CVWD doing some of the work for them, Jagers said. Covington noted it is unlikely that anyone would support the state returning the mcl to what had been set previously. The state must prove their case, he added. Mr. Jagers noted there is a public workshop in Diamond Bar that he plans to attend.

Production numbers are up, as it has been hot, Jagers advised.

### c. Directors' Reports:

Director Ramirez said he is looking forward to seeing the division-specific pages available on the website as quickly as possible from CV Strategies.

d. Legal Counsel Report: None.

## 9. Announcements

*President Covington read the following announcements:*

- Personnel Committee meeting: Monday, March 23, 2020 at 5:30 p.m.
- Engineering Workshop: Thursday, March 26, 2020 at 6:00 p.m.
- Beaumont Basin Watermaster Committee: Wednesday, April 1, 2020 at 10 a.m.
- Finance and Audit Committee Meeting: Thursday, April 2, 2020 at 3:00 p.m.
- Regular Board Meeting: Wednesday, April 8, 2020 at 6:00 p.m.

## 10. Action List for Future Meetings:

- Beaumont Master Drainage Plan Line 16 agreement
- Closed Session re: General Manager Evaluation

## 11. Convened in Closed Session: 7:04 p.m.

*President Covington left the meeting.*

- a. CONFERENCE WITH LEGAL COUNSEL – Anticipated Litigation Pursuant to Government Code Section 54956.9(d)(4)  
One Potential Case

Reconvened in Open Session: 7:08 p.m.

### Report on Closed Session

*Legal Counsel James Markman reported that a temporary chair was appointed.*

*Temporary Chair Daniel Slawson announced there was no reportable action taken during Closed Session.*

## 12. Adjournment

*Temporary Chair Slawson adjourned the meeting at 7:09 p.m.*

ATTEST:

*DRAFT UNTIL APPROVED*

*DRAFT UNTIL APPROVED*

---

Director John Covington, President  
to the Board of Directors of the  
Beaumont-Cherry Valley Water District

---

Director Lona Williams, Secretary  
to the Board of Directors of the  
Beaumont-Cherry Valley Water District



**BEAUMONT-CHERRY VALLEY WATER DISTRICT**  
560 Magnolia Avenue, Beaumont, CA 92223

**MINUTES OF REGULAR MEETING – ENGINEERING WORKSHOP  
OF THE BOARD OF DIRECTORS**  
Thursday, March 26, 2020 at 6:00 p.m.

*Meeting held via teleconference pursuant to  
California Government Code Section 54950 et. seq. and  
California Governor's Executive Order N-29-20*

---

**Call to Order: President Covington**

*President Covington began the meeting at 6:03 p.m.*

*Pledge of Allegiance was led by Vice President Slawson.*

*Invocation was given by Director Hoffman.*

**Announcement of Teleconference Participation**

Director of Finance and Administration Yolanda Rodriguez clarified that this meeting is conducted via teleconference pursuant to California Government Code Section 54953, and under Executive Order N-29-20 and N-33-20 of the Governor of California.

The teleconference capabilities of this meeting have been identified in the Notice and Agenda for this meeting, pursuant to the Brown Act and the Governor's Executive Order. Under the Governor's Executive Order and the Gathering Guidelines of the California Department of Health due to the danger of COVID-19, the teleconference locations are not publicly accessible. The public's right to comment and participate in the meeting is being assured via teleconference capabilities.

The Beaumont-Cherry Valley Water District (BCVWD) will use sound discretion and make reasonable efforts to adhere as closely as reasonably possible to the provisions of the Brown Act, and other applicable local laws regulating the conduct of public meetings, in order to maximize transparency and provide the public access to meetings.

**Roll Call:**

Directors present:	Covington, Hoffman, Slawson, Ramirez, Williams
Directors absent:	None
Staff present:	General Manager Dan Jagers Director of Finance and Administration and Recording Secretary Yolanda Rodriguez Senior Engineer Mark Swanson



	Senior Finance and Administrative Analyst William Clayton Assistant Director of Operations James Bean Administrative Assistant Erica Gonzales Human Resources Coordinator Sabrina Foley
Legal Counsel	Not present

Members of the public who registered their attendance: Dr. Blair Ball.

Director of Finance and Administration Yolanda Rodriguez verified that all members of the Board of Directors have indicated that they are able to hear the other directors clearly on the teleconference. No directors expressed any reason to believe, based on voice recognition or otherwise, that those persons representing themselves to be directors are not truly so.

**Public Comment:** None.

### ADJUSTMENTS TO THE AGENDA

EMERGENCY ITEM: President Covington advised the Board that an emergency item came to the attention of staff after the posting of the agenda. Pursuant to California Government Code Section 54954.2 (b), the Board may make a finding that there is need for immediate action and may vote to add the item to the agenda.

Covington provided a description of the pending action of the U.S. House of Representatives on a bipartisan \$2 trillion emergency package to address the impacts of COVID-19. He noted the California Special Districts Association has analyzed the bill and recommends action by sending a letter to representatives. He called for a motion to add the item to the agenda as Item 8.

*The Emergency Item was added as Agenda Item 8 by the following roll call vote:*

MOVED: Hoffman	SECONDED: Slawson	APPROVED 5-0
AYES:	Covington, Hoffman, Ramirez, Slawson, Williams	
NOES:	None.	
ABSTAIN:	None.	
ABSENT:	None.	

### 1. PUBLIC HEARING: Ordinance 2020-01: Introduce, Waive Reading, and Place on Agenda for Adoption Ordinance 2020-01: Providing for Compensation of the Members of the Board of Directors of the Beaumont-Cherry Valley Water District and Superseding Ordinance 2007-01

General Manager Jagers reminded the Board of its request for a public hearing in accordance with the consideration of adjusting the compensation for members of the Board from \$200 to \$260 per day of service. The public hearing has been advertised in accordance with California law, he noted. Staff has recommended the public hearing be continued to May 13, 2020 due to the limits of teleconferencing given the California Department of Public Health Gathering Guidelines regarding the COVID-19 respiratory illness in an effort to be fully transparent. Alternatively, the Board may waive the reading of the ordinance and proceed with consideration.

President Covington opened the floor for public comment.

Dr. Blair Ball said he hoped the Board would continue the public hearing to the meeting of May 13 to enable a face-to-face agenda item. These are unusual times, he continued, and this is not an urgent or an emergency item.

Mr. Jagers polled the Board members to assure they heard the comment from Dr. Ball; all indicated they had heard.

President Covington called for Board comment.

Director Hoffman suggested following staff's recommendation for continuance since this is not an emergency and to allow the public more time to consider. Director Slawson concurred.

Director Ramirez stated that he believes thorough due diligence has been done by staff and the committee, and said he sees no need to postpone.

*The Board waived the first reading and placed Ordinance 2020-01 Providing for Compensation of the Members of the Beaumont-Cherry Valley Water District Board of Directors and Superseding Ordinance 2007-01 on the Beaumont-Cherry Valley Board of Directors Regular Meeting agenda of April 8, 2020 at 6 p.m. for adoption by the following roll call vote:*

MOVED: Ramirez	SECONDED: Williams	APPROVED 5-0
AYES:	Covington, Hoffman, Ramirez, Slawson, Williams	
NOES:	None.	
ABSTAIN:	None.	
ABSENT:	None.	

**2. Resolution 2020-06 Implementing a Temporary Meeting Teleconference Policy in Response to the Impact of the Respiratory Illness Pandemic COVID-19**

General Manager Jagers explained this is a temporary teleconference policy in response to the impact of COVID-19. Staff has prepared a resolution that identifies the issues and sets forth the changes. He noted that it makes some changes to the District's Policies and Procedures Manual to provide for Governor Gavin Newsom's various declarations regarding the state of emergency and implementation of strong measures to curtail the spread of the virus.

Jagers advised that this proposed policy addresses Gov. Newsom's Executive Orders N-25-20 and N-29-20 which suspend certain activities to minimize public exposure as well as make meetings inaccessible other than via teleconferencing. Staff believes this addresses all measures set forth in those orders, he said.

In addition, this parallels a current proclamation of local emergency by the General Manager, he advised.

*The Board adopted Resolution 2020-06 Implementing a Temporary Meeting Teleconference Policy in Response to the Impact of the Respiratory Illness Pandemic COVID-19 by the following roll call vote:*

MOVED: Slawson	SECONDED: Hoffman	APPROVED 5-0
AYES:	Covington, Hoffman, Ramirez, Slawson, Williams	
NOES:	None.	
ABSTAIN:	None.	
ABSENT:	None.	

**3. Resolution 2020-07: Ratifying and Proclaiming a District Local Emergency in Response to the Impact of the Respiratory Illness Pandemic COVID-19**

General Manager Jagers explained the request for ratification of a District Local Emergency in accordance with the District’s Policies and Procedures in response to the impact of COVID-19. He reminded the Board of the local emergencies referenced in the Resolution. The General Manager’s declaration must be ratified by the Board within 14 days, Jagers noted.

During the local emergency, it is important to protect ratepayers and staff by taking certain actions, and this allows the ability to mobilize local resources for interagency response, accelerate procurement of vital supplies, use mutual aid and seek future reimbursement from the state and federal government, which will be critical to the successful response to COVID-19, Jagers explained.

Jagers pointed out the statement of findings and noted the District has already taken action but there is continued uncertainty and staff is requesting the Board ratify the General Manager’s proclamation.

President Covington asked if this puts the District in a position for recoup of any funding utilized for the purpose of battling COVID-19; Mr. Jagers explained this provides an opportunity for the District to request local and federal funding. Work orders have been identified for these activities such as remote work to minimize staff exposure. It could also include temporary staff, he added.

*The Board adopted Resolution 2020-07 Ratifying and Proclaiming a District Local Emergency in Response to the Impact of the Respiratory Illness Pandemic COVID-19 by the following roll call vote:*

MOVED: Slawson	SECONDED: Williams	APPROVED 5-0
AYES:	Covington, Hoffman, Ramirez, Slawson, Williams	
NOES:	None.	
ABSTAIN:	None.	
ABSENT:	None.	

**4. Resolution 2020-08: Implementing Temporary Policies, Actions and Measures in Response to the District Local Emergency Regarding the Respiratory Illness Pandemic COVID-19**

Mr. Jagers explained the District has identified needs and requests Board authorization in advance in order to protect and promote employee safety and is working to adhere to the Guidelines from the California Department of Public Health that suggest social distance of at least six feet. Staff recommends the adoption of the proposed measures in Exhibit A, Jagers stated.



To clarify, Jagers continued, the administration office facility has been closed on a week-by-week basis, and it is intended to continue to do so. The District will parallel current best practices as recommended by state, local and federal governments, he noted. These are being reassessed weekly by the GM and Board President, Jagers assured. Other opportunities have been offered to the public for bill payment, he said. The intent of these temporary policies is to give the GM the authority to furlough non-essential employees to minimize exposure to risk, and to comply with local health department requirements.

The District is identified as a critical facility, Jagers explained. Five laptops were purchased, and desktop computers have been issued for remote work conditions, he noted resulting in 20 to 25 percent density at the office. The 4/10 workweek has also been altered to minimize contact.

Staff also requests the Board allow for employees to be considered for eligible paid emergency leave of up to 140 hours for full time employees and proportionate leave for part time employees as approved on a case-by-case basis, Jagers noted. He described the policies and stressed the goal of keeping employees well and minimizing exposure in order to ensure a healthy workforce and continuity of service to customers.

In response to President Covington, Mr. Jagers detailed logistical considerations of paid emergency leave for employee illness and indicated this is determined on a case-by-case basis. The District wants to assure an employee enough time to stay home until they are able to return to work with a clean bill of health, he said. Emergency leave is included in the District’s existing general policy provisions, he responded. President Covington asked about funding for the 140 hours and use of existing employee sick leave and vacation pay. Mr. Jagers indicated it would be expected that employees would utilize those benefits and the 140 hours provides opportunity to assure an employee is healthy before returning to work in order to maintain a healthy staff.

Human Resources Coordinator Sabrina Foley added that the intention of the emergency leave policy is to assist the District in complying with the Families First Act recently approved by Congress. The legislation requires the District to provide additional forms of leave in addition to an employee’s established benefit of sick and vacation time, she explained.

*The Board adopted Resolution 2020-08 Implementing Temporary Policies, Actions and Measures in Response to the District Local Emergency Regarding the Respiratory Illness Pandemic COVID-19 by the following roll call vote:*

MOVED: Williams	SECONDED: Slawson	APPROVED 5-0
AYES:	Covington, Hoffman, Ramirez, Slawson, Williams	
NOES:	None.	
ABSTAIN:	None.	
ABSENT:	None.	

**5. Resolution 2020-09: Approving Temporary Regulations Regarding Customer Account Billing and Collections in Response to the District Local Emergency Regarding the Respiratory Illness Pandemic COVID-19**

Director of Finance and Administration Yolanda Rodriguez referenced Governor Newsom’s Executive Order N-28-20 requesting the California public Utilities Commission monitor measures undertaken by public utility providers to implement customer service protections for water utilities in response to COVID-19. She noted that many public water utilities are instituting ratepayer protections and detailed the findings for consideration.

Ms. Rodriguez asked the Board to temporarily supersede current District Rules and Regulations Part 6 per Exhibit A, including closure of the office to the public, suspension of the online payment fee, extension of payment grace period, delay in imposition of penalties for non-payment, no application of late fees, and no disconnections during the proclaimed local emergency.

*The Board adopted Resolution 2020-09 Approving Temporary Regulations Regarding Customer Account Billing and Collections in Response to the District Local Emergency Regarding the Respiratory Illness Pandemic COVID-19 by the following roll call vote:*

MOVED: Williams	SECONDED: Slawson	APPROVED 5-0
AYES:	Covington, Hoffman, Ramirez, Slawson, Williams	
NOES:	None.	
ABSTAIN:	None.	
ABSENT:	None.	

**6. Ratification of the General Manager’s Declaration of a District Emergency regarding Necessary Immediate Repairs to Well 21**

General Manager Jagers reminded the Board about the report at the last meeting on Well 21 being out of service due to significant vibration. Staff considered the work needed and the uncertainties regarding the COVID-19 coronavirus outbreak and the possibility that the work pool and/or materials and equipment supplies may be depleted in the coming months when demand increases. District management has identified that repairs to Well 21 are of critical interest to the District. Mr. Jagers indicated that President Covington concurred.

District policy provides for a declaration of emergency by the general manager, Jagers continued. This allows the GM to suspend some public bid aspects of policies and procedures and to provide resources that may not otherwise be available. Staff recommends the ratification of the emergency.

Mr. Jagers said staff solicited and received four informal bids that seem reasonable and are in accordance with those from previous projects. Mr. Jagers said that President Covington has seen the information, and requested ratification of the emergency and authorization for the negotiation with the lowest responsive bidder (Legend Pump and Well Services, Inc.) to move forward with a contract for repair.

President Covington noted that the informal bids comported with what would normally be found for a well of that size and capacity, in the range of \$250,000. He

said he believes the cost will actually be well under that amount. He explained contingencies that would be covered by the funding and said he asked GM Jagers to work with Legend to narrow the cost of repair after inspection.

This allows the General Manager the authority to proceed without delay until the actual costs are evident, then he will bring that back to the Board, Covington explained.

Director Ramirez clarified the authorization for the GM to make expenditures up to \$250,000 on emergency repairs. Mr. Jagers noted this is per District policy. He said he anticipates the cost will be less, the emergency limit of \$250,000 is a policy limit not a case-particular limit. The Board action is to ratify the emergency, Jagers explained.

*The Board ratified the General Manager’s Declaration of a District Emergency to address the necessary immediate repairs to Well 21 in accordance with the District’s Policy and Procedures by the following roll call vote:*

MOVED: Slawson	SECONDED: Williams	APPROVED 5-0
AYES:	Covington, Hoffman, Ramirez, Slawson, Williams	
NOES:	None.	
ABSTAIN:	None.	
ABSENT:	None.	

**7. Authorize the General Manager to Award a Contract to Red Hawk Services, Inc. in an Amount not to Exceed \$92,566.00 for the Noble Creek Recharge Facilities Phase I Fencing Project**

Mr. Jagers explained this is the opportunity to provide added security for the Noble Creek Recharge Facilities Phase I on the east side of Beaumont Avenue between Brookside Avenue and Cherry Valley Boulevard. It includes the white picket fence area, ponds and 28 acres of facilities and walkways.

Jagers referenced the previous project discussions before the Board. Fencing options were researched and bid, he explained. Mr. Jagers reviewed bid schedules as presented in the staff report and recommended the galvanized chain link option, as all other fencing in the area is this material except a small amount of wrought iron.

President Covington recalled that several fence material options were previously presented but were more expensive. In response to Covington, Jagers assured this is commercial grade fencing, and noted that staff selected a heavier gauge material. Jagers also noted a continuing issue with entry holes being cut in the fence at Phase II which appear to be made by high school students.

Director Williams expressed a preference for the 8-foot height fence and noted the barbed wire top may not be a deterrent to those cutting the fence to walk through. Director Ramirez asked if this was the fencing material similar to the Redlands fence previously discussed; Covington said it is not. Those types of materials were bid, Covington explained, and the cost was around \$250,000. The Board settled with chain link, he said. In addition, he noted that the San Gorgonio Pass Water Agency added chain link along their nearby facility.

Director Ramirez pointed out the same problem of fence cutting would be encountered with chain link; it will be an ongoing issue. He suggested looking at wrought iron for durability and said he does not believe chain link is the way to go.

Noble Creek Phase II and Riverside County Flood Control's fencing is chain link, Mr. Jagers confirmed in response to Covington.

Director Hoffman pointed out that the facility was originally designed to be open to the public. He reiterated the concern for liability and noted it will still have liability considerations as it is opened for the fishing derby every year. In addition, access is easily gained by merely cutting the fence, he said. Hoffman said he would like to find out about liability issues and cost of insurance coverage. He suggested a report from legal counsel regarding liabilities with or without fencing. He also suggested leaving gates open to allow public access during the day.

VP Hoffman said he regularly walks the property and it seems things are now calm and secure during the daytime but acknowledged exposure. If the Board did decide to go with fencing, he said, wrought iron would be best but it is a big expense and should be further evaluated.

Director Slawson referenced the access via cutting of the fence and said the District may not have liability as the entry is trespassing and breaking in. The District's exposure is covered by having the fence even if it were being cut. He said it would be a travesty to erect a fence and lose the hiking trails and foliage that were for the public, but he also wants to protect the District, he said. He said he supports a chain link fence, as wrought iron or block wall is much too expensive and it is the responsibility of the board to look after the District fiscally.

President Covington requested legal counsel's analysis on the District's exposure to liability on the Recharge facility and other District property prior to moving forward. The Board directed staff to remove the park benches and barbecues and to add rocks to prevent driving onto the property, he reminded. He also noted that it was the concern of former Director Diaz to secure the property due to the proximity of the junior high and high schools.

President Covington suggested tabling the item and requested a legal analysis to achieve buy-in on the project.

Director Hoffman concurred. Mr. Jagers asked the Board to drive the area and look at the existing situation and visualize a fence over the existing terrain and landscaping. He reminded the Board that different types of fencing had been evaluated over the past year of consideration and what was determined is where this project is today. Data is available from the past Board meetings and if review is warranted it can be done.

President Covington tabled the item. Mr. Jagers said it would be brought back quickly, as there is an open bid on the project and a fixed timeline to make a decision or re-bid. Covington requested the bid alternative numbers to be resubmitted to the Board.

Director Ramirez requested a bid for wrought iron fencing. Mr. Jagers indicated there is a cost estimate available.

President Covington complimented staff on the design work.

**8. EMERGENCY ITEM:**

**Letter to the District’s Congressional Representatives regarding the emergency package to address the impacts of COVID-19 as requested by the California Special Districts Association**

Mr. Jagers explained this is regarding Board authorization to write a letter. Last night, the U.S. Senate passed a bipartisan \$2 trillion emergency package to address the impacts of COVID-19. The bill now moves to the House of Representatives. The California Special Districts Association has analyzed the bill and recommends special districts take action by sending a letter to their representatives, he said.

This is an emergency item as action is moving quickly, Jagers explained. The CSDA provided a draft letter which requests elected officials to request the additional prospective federal aid package include supplemental appropriations measures to address the economic impact of COVID-19 to include special districts, Jagers noted. He reviewed additional points of the draft letter and noted the intent is to get the letter out tomorrow if approved.

*The Board approved the execution and sending of a letter to the District’s Congressional Representatives regarding the emergency package to address the impacts of COVID-19 as requested by the California Special Districts Association by the following roll call vote:*

MOVED: Ramirez	SECONDED: Williams	APPROVED 5-0
AYES:	Covington, Hoffman, Ramirez, Slawson, Williams	
NOES:	None.	
ABSTAIN:	None.	
ABSENT:	None.	

**9. General Manager’s Report**

General Manager Jagers advised that a little over 3,000 acre-feet of water was delivered to the Noble Creek Recharge Facility so far this year. He discussed with President Covington the potential of suspending deliveries for the next couple of weeks to minimize impact of non-critical activities to the staff and to avoid having staff members of other entities required to work the short-term recharge.

Jagers said he has reviewed the water order and he believes the full 2020 water order can be recharged and therefore has suspended water deliveries in the short term without risk or adverse effect.

Work is ongoing at 9<sup>th</sup> and 11<sup>th</sup> streets, Jagers reported. The District’s contractor has replaced all the mainline pipe and pressure tested one which passed; the other will be done tomorrow, he said. He expects to be out of the way of the City of Beaumont’s paving project for Beaumont Avenue which is moving ahead.

BCVWD employees are healthy and working remotely as much as possible, Jagers added. Everything possible is being done to minimize contact with the public to protect employees from risk. Employees have a great attitude



considering all the uncertainty and BCVWD is committed to providing uninterrupted water supply to the area, Jagers concluded.

## 10. Topics for Future Meetings:

Contract to Red Hawk Services, Inc. in an Amount not to Exceed \$92,566.00 for the Noble Creek Recharge Facilities Phase I Fencing Project – Item 7 tabled by President Covington

Consideration of Board meeting schedule and preparation for any needed supplemental meetings

## 11. Announcements

*All the following meetings will be held via teleconference unless otherwise indicated. President Covington read the following announcements:*

- Personnel Committee: Postponed to Monday, March 30 at 5:30 p.m.
- Watermaster Meeting for April 1, 2020 is CANCELLED
- Finance and Audit Committee Meeting: Thursday, April 2 at 3 p.m.
- Regular Board Meeting: Wednesday, April 8, 2020 at 6:00 p.m.
- Engineering Workshop: Thursday, April 23, 2020 at 6:00 p.m.
- Collaborative Agencies Committee Meeting: Wednesday, May 6 at 5:00 p.m. (teleconference unknown)
- Finance and Audit Committee Meeting: Thursday, May 7, 2020 at 3:00 p.m.
- District offices will be closed on Monday, May 25 in observance of Memorial Day
- Personnel Committee: No meeting in May due to Memorial Day holiday

President Covington thanked staff for coordinating the teleconference and deemed it a success. He also thanked administrative and field staff for their dedication during the COVID-19 situation.

## 12. Adjournment

*President Covington adjourned the meeting at 7:57 p.m.*

ATTEST:

*DRAFT UNTIL APPROVED*

*DRAFT UNTIL APPROVED*

---

Director John Covington, President  
to the Board of Directors of the  
Beaumont-Cherry Valley Water District

---

Director Lona Williams, Secretary  
to the Board of Directors of the  
Beaumont-Cherry Valley Water District



**Beaumont-Cherry Valley Water District  
Regular Board Meeting  
April 8, 2020**

Item 2g

STAFF REPORT

**TO:** Board of Directors  
**FROM:** Dan Jagers, General Manager  
**SUBJECT:** **Waive Second Reading and Adopt Ordinance 2020-01: Providing for Compensation of the Members of the Board of Directors of the Beaumont-Cherry Valley Water District and Superseding Ordinance 2007-01**

---

**Staff Recommendation**

Waive the second reading of Ordinance 2020-01 and adopt Ordinance 2020-01 Providing for Compensation of the Members of the Beaumont-Cherry Valley Water District Board of Directors and Superseding Ordinance 2007-01

**Summary**

At its November 25, 2019 meeting, the Personnel Committee directed staff to bring back consideration of the per diem to the full Board with several options, and at its December 18, 2019 meeting the Board chose to move forward with consideration of a per diem increase to \$260.

Per the requirements of Water Code Sections 20201 – 20203, a public hearing was held on March 26, 2020 and the Board of Directors voted to place Ordinance 2020-01 on this agenda for adoption.

**Attachment(s)**

- Ordinance 2020-01 Providing for Compensation of the Members of the BCVWD Board of Directors and Superseding Ordinance 2007-01
- Proof of Publication

DKJ:ljc

## ORDINANCE 2020-\_\_

### **AN ORDINANCE OF THE BOARD OF DIRECTORS OF THE BEAUMONT - CHERRY VALLEY WATER DISTRICT PROVIDING FOR COMPENSATION OF THE MEMBERS OF THE BOARD OF DIRECTORS OF THE DISTRICT AND SUPERSEDING ORDINANCE 2007-01**

**WHEREAS**, Section 20201 of the California Water Code states that compensation to be received by the governing board of a water district may be increased each calendar year in an amount equal to 5 percent following the operative date of the last adjustment; and

**WHEREAS**, the Board of Directors of the Beaumont-Cherry Valley Water District last increased its compensation pursuant to Water Code Section 20200 et. seq. on December 12, 2007; and

**WHEREAS**, a duly noticed public hearing was held on March 26, 2020 to receive and consider public comments regarding the adoption of an ordinance to amend the per diem compensation for the members of the Beaumont-Cherry Valley Water District Board of Directors; and

**WHEREAS**, this Ordinance was presented to the Board of Directors and was reviewed thoroughly and found to be acceptable to the Board,

### **NOW THEREFORE, THE BOARD OF DIRECTORS OF THE BEAUMONT-CHERRY VALLEY WATER DISTRICT DOES HEREBY ORDAIN AS FOLLOWS:**

1. Ordinance 2007-01 and all other previously enacted ordinances providing for Board of Directors compensation are hereby superseded by this Ordinance.
2. Director compensation shall be \$260 for each day's service rendered (per diem) as a Director on behalf of the District.
3. The payment of Director compensation shall be governed by the Beaumont-Cherry Valley Water District Policies and Procedures Manual, Part II, Section 13.
4. In no event shall members of the Board of Directors receive compensation for more than ten (10) days' service in any calendar month, pursuant to Water Code Section 20202.
5. This Ordinance will take effect on July 1, 2020, which is at least sixty (60) days from the date of adoption pursuant to Water Code Section 20204.
6. If any section, subsection, clause or phrase in this Ordinance is for any reason held invalid, the validity of the remainder of this Ordinance shall not be affected thereby.
7. The Recording Secretary is hereby directed to cause this Ordinance to be published once in full in a newspaper of general circulation within the District.



**ADOPTED** this 8th day of April, 2020 by the following vote:

AYES:  
NOES:  
ABSTAIN:  
ABSENT:

ATTEST:

\_\_\_\_\_  
Director John Covington, President of the  
Board of Directors of the  
Beaumont-Cherry Valley Water District

\_\_\_\_\_  
Director Lona Williams, Secretary to the  
Board of Directors of the  
Beaumont-Cherry Valley Water District

DRAFT

Record Gazette  
218 N. Murray St.  
**Proof of Publication**  
(2015.5 C.C.P.)

174404 PHN ORD 2020-01

State of California )  
County of Riverside ) ss.

I am a citizen of the United States and a resident of the State of California; I am over the age of eighteen years, and not a party to or interested in the above matter. I am the principal clerk of the printer and publisher of Record Gazette, a newspaper published in the English language in the City of Banning, County of Riverside, and adjudicated a newspaper of general circulation as defined by the laws of the state of California by the Superior Court of the County of Riverside, under the date October 14, 1966, Case No. 54737. That the notice, of which the annexed is a copy, has been published in each regular and entire issue of said newspaper and not in any supplement thereof on the following dates, to-wit:

March 13, 20, 2020

Executed on: 03/20/2020

At Banning , CA

I certify (or declare) under penalty of perjury that the foregoing is true and correct.

  
\_\_\_\_\_  
Signature

NOTICE OF PUBLIC HEARING FOR THE APPROVAL ORDINANCE 2020-01 NOTICE IS HEREBY GIVEN THAT THE Board of Directors of the Beaumont Cherry Valley Water District will hold a Public Hearing at their March 26, 2020, Regular Meeting to take public comment on compensation of the Board of Directors.

**PUBLIC MEETING/PUBLIC HEARING**

NOTICE IS HEREBY GIVEN THAT ON MARCH 26, 2020, AT THE HOUR OF 6:00 P.M. OF SAID DAY, AT THE REGULAR MEETING PLACE OF THE BOARD OF DIRECTORS OF THE DISTRICT, 560 MAGNOLIA AVE., BEAUMONT, CALIFORNIA, IS THE TIME AND PLACE FIXED TO CONSIDER AND FINALLY DETERMINE WHETHER OR NOT TO APPROVE ORDINANCE 2020-01, ORDINANCE OF THE BOARD OF DIRECTORS OF THE BEAUMONT CHERRY VALLEY WATER DISTRICT PROVIDING FOR COMPENSATION OF MEMBERS OF THE BOARD OF DIRECTORS OF THE DISTRICT AND SUPERSEDING ORDINANCE 2007-01.

Published in  
The Record Gazette  
No. 174404  
03/13, 20, 2020



**Beaumont-Cherry Valley Water District  
Regular Board Meeting  
April 8, 2020**

Item 3

STAFF REPORT

**TO:** Board of Directors  
**FROM:** Dan Jagers, General Manager  
**SUBJECT:** **Consideration of Attendance at the Association of California Water Agencies Annual Spring Summer Conference in Monterey, CA from July 28 – 31, 2020**

**Staff Recommendation**

Consider attendance of members of the Board of Directors and / or staff to represent BCVWD at the ACWA Summer Conference, to be held July 28 – 31, 2020 in Monterey, California.

**Background**

The Beaumont-Cherry Valley Water District (BCVWD) Policies and Procedures Manual Part II, Section 12 A states:

Members of the Board of Directors are encouraged to attend educational conferences and professional meetings when the purposes of such activities are to improve District operation. Hence, there is no limit as to the number of Directors attending a particular conference or seminar when it is apparent that their attendance is beneficial to the District.

Attendance at the ACWA conferences can be beneficial to the District. With the availability of grant opportunities, BCVWD’s participation in the Sites Reservoir project, and the endeavor to minimize imported water costs, the ACWA conference provides a forum to learn about issues, best practices and to make strategic contacts. It would serve BCVWD to be well informed.

This conference is normally called the “Spring Conference” and is held in May; however due to the onset of the COVID-19 pandemic and related regulations on large gatherings, the conference has been postponed to July.

The deadline to register is July 10, 2020. Hotel room blocks in Monterey sell out quickly. Interested directors should advise staff of their desire to attend as soon as possible.

**Fiscal Impact**

Estimated cost per conference attendee:

Conference registration with meal package	725.00
Hotel (check in 7/27/20, check out 7/31/20 = 4 nights @ \$237 + tax) est.	1,185.00
Meals and incidentals (4.5 days: 3 dinners, 3 breakfasts*)	156.00
Transportation: (personal vehicle 800 miles RT @ 57.5 cents/mile)**	460.00
<b>OR</b> Transportation: Airfare ONT – San Jose, plus rental car (5 days)***	854.00
Director per diem (5 days @ \$260 per day)	1,300.00
Estimated cost per conference attendee (driving)	<b>\$3,826.00</b>
Estimated cost per conference attendee (flying)	<b>\$4,220.00</b>

\*U.S. General Services Administration per diem rates for Monterey = \$18 breakfast, \$34 dinner

\*\*IRS standard mileage rate for 2020

\*\*\* Airfare retrieved on 3/24/2020. Greatly subject to change.



District staff shall register the Directors who wish to attend and will arrange lodging. District Policy states that costs of transportation, meals and incidentals incurred while serving the District shall be reimbursed with submittal of reimbursement form, explanation of expenses and original receipts. A travel advance may be requested in writing and submitted to the Board for approval.

### **Attachments**

BCVWD Policies and Procedures Manual Part II, Section 12  
Preliminary Conference Agenda

Report prepared by Lynda Kerney, Administrative Assistant

refer to committee, which is then seconded and approved by a majority vote of the Board.

- v. **Motion to Close Debate and Vote Immediately.** As provided above, any Director may move to close debate and immediately vote on a main motion.
- vi. **Motion to Adjourn.** A meeting may be adjourned by motion made, seconded, and approved by a majority vote of the Board before voting on a main motion.

F. **Decorum.**

- i. The President shall take whatever actions are necessary and appropriate to preserve order and decorum during Board meetings, including public hearings.
- ii. The President may also declare a short recess during any meeting.

G. **Amendment of Rules of Order.** By motion made, seconded and approved by a majority vote, the Board may, at its discretion and at any meeting:

- a. Temporarily suspend these rules in whole or in part;
- b. Amend these rules in whole or in part; or,
- c. Both.

## 12. TRAINING, EDUCATION AND CONFERENCES

A. **Policy.** The Beaumont-Cherry Valley Water District takes its stewardship over the use of limited public resources seriously. Public resources should only be used when there is a substantial benefit to the District.

- i. Educational conferences and professional meetings are considered to provide substantial benefit. Members of the Board of Directors are encouraged to attend educational conferences and professional meetings when the purposes of such activities are to improve District operation. Hence, there is no limit as to the number of Directors attending a particular conference or seminar when it is apparent that their attendance is beneficial to the District. Such benefits include:
  - a. The opportunity to discuss the community's concerns with state and federal officials;
  - b. Participating in regional, state and national organizations whose activities affect the District;

- c. Attending educational seminars designed to improve officials' skill and information levels;
    - d. Promoting public service and morale by recognizing such service.
  - ii. "Junkets" (a tour or journey for pleasure at public expense), however, will not be permitted.
- B. **Expenses.** It is the policy of the District to encourage Board development and excellence of performance by reimbursing actual expenses incurred for tuition, travel, lodging and meals as a result of training, educational courses, participation with professional organizations, and attendance at local, state and national conferences associated with the interests of the District.
  - i. Staff as assigned by the General Manager is responsible for making arrangements for Directors for conference and registration expenses.
  - ii. Reimbursement shall include expenses for meals, lodging, authorized incidentals (see Section 14H) and travel. All expenses for which reimbursement is requested by Directors, or which are billed to the District by Directors, shall be submitted to the assigned staff member within 30 days of the incurred expense on a District-supplied Expense Form, together with original, valid receipts in accordance with State law.
  - iii. Attendance by Directors of seminars, workshops, courses, professional organization meetings, and conferences shall be approved by the Board of Directors prior to incurring any reimbursable costs.
  - iv. Expenses to the District for Board of Directors' training, education and conferences should be kept to a minimum by utilizing recommendations for transportation and housing accommodations put forth, if any, by the event sponsor and by:
    - a. Utilizing hotel(s) recommended by the event sponsor in order to obtain discounted rates or using other less expensive nearby lodging.
    - b. Directors traveling together whenever feasible and economically beneficial.
    - c. Requesting reservations sufficiently in advance, when possible, to obtain discounted air fares and hotel rates.
- C. **Notice.** A Director shall not attend a conference or training event for which there is an expense to the District, if it occurs after the Director has announced his/her pending resignation, or if it occurs after an election in which it has been determined that the Director will not retain his/her seat on the Board. A Director shall not attend a conference or training event when it is apparent that there is no significant benefit to the District.



# ACWA 2020 Spring Conference & Exhibition

## PRELIMINARY AGENDA

July 28 - 31, 2020 • Monterey, CA

### ACWA JPIA - MONDAY, JULY 27

- 8:30 - 10:00 AM**
  - ACWA JPIA Program Committee
- 10:15 - 11:15 AM**
  - ACWA JPIA Executive Committee
- 1:30 - 4:00 PM**
  - ACWA JPIA Board of Directors
- 4:00 - 5:00 PM**
  - ACWA JPIA Town Hall
- 5:00 - 6:00 PM**
  - ACWA JPIA Reception

### TUESDAY, JULY 28

- 8:00 AM - 9:45 AM**
  - Agriculture Committee
- 8:00 AM - 6:00 PM**
  - Registration
- 8:30 AM - Noon**
  - ACWA JPIA Seminars
- 9:00 AM - 4:00 PM**
  - ACWA Legal Briefing & CLE Workshop
- 10:00 - 11:45 AM**
  - Groundwater Committee
  - Local Government Committee
- 11:00 AM - Noon**
  - Outreach Task Force
- Noon - 2:00 PM**
  - ACWA 101 & Luncheon
  - Committee Lunch Break
- 1:00 - 2:45 PM**
  - Energy Committee
  - Finance Committee
  - Water Management Committee
- 1:00 - 3:00 PM**
  - ACWA JPIA: Sexual Harassment Prevention for Board Members & Managers (AB 1825)
- 3:00 - 4:45 PM**
  - Communications Committee
  - Federal Affairs Committee
  - Membership Committee
  - Water Quality Committee

### WEDNESDAY, JULY 29

- 7:30 AM - 5 PM**
  - Registration
- 8:00 - 9:45 AM**
  - Opening Breakfast (*Ticket Required*)

### WEDNESDAY, JULY 29 (continued)

- 7:30 AM - Noon & 1:30 - 6:00 PM**
  - Exhibit Hall
- 7:30 - 8:30 AM**
  - Coffee Service in the Exhibit Hall
- 10:00 - 11:30 AM**
  - Attorneys Program
  - Energy Committee Program
  - Exhibitor Demos
  - Finance Program
  - Region Issue Forum
  - Statewide Issue Forum
  - Technology Program
  - Water Industry Trends Program
- 11:30 - NOON**
  - Networking in the Exhibit Hall
- NOON - 1:45 PM**
  - General Session Luncheon (*Ticket Required*)
- 2:00 - 3:15 PM**
  - Attorney Program
  - Communications Committee Program
  - Energy Committee Program
  - Exhibitor Case Study
  - Region Program
  - Statewide Issue Forum
  - Water Industry Trends Program
- 3:30 - 4:45 PM**
  - Exhibitor Case Study
  - Finance Program
  - Local Government Committee
  - Statewide Issue Forums
  - Technology Program
  - Water Industry Trends Program
- 3:30 - 5:30 PM**
  - Legal Affairs Committee
- 5:00 - 6:00 PM**
  - Prize Drawing Fiesta Night in the Exhibit Hall
- 5:30 - 7:00 PM**
  - CalDesal Hosted Mixer
  - Jacobs Hosted Reception

### THURSDAY, JULY 30

- 7:30 AM - 4:00 PM**
  - Registration
- 7:45 - 9:15 AM**
  - Regions 6-10 Membership Meetings
- 8:00 AM - Noon**
  - Exhibit Hall
- 8:00 - 9:15 AM**
  - Networking Continental Breakfast, Exhibit Hall (*Ticket Required*)

### THURSDAY, JULY 30 (continued)

- 8:30 - 10:45 AM**
  - Ethics Training (AB 1234) - *Limited Seating*
- 9:30 - 11:00 AM**
  - Attorneys Program
  - Exhibitor Demos
  - Finance Program
  - Human Resource Program
  - Region Issue Forum
  - Statewide Issue Forum
  - Water Industry Trends Program
- 11:00 - 11:45 AM**
  - Prize Drawings in the Exhibit Hall
- NOON - 1:45 PM**
  - General Session Luncheon (*Ticket Required*)
- 2:00 - 3:15 PM**
  - Attorneys Program
  - Exhibitor Case Studies
  - Federal Issues Forum
  - Human Resource Program
  - Statewide Issue Forum
  - Water Industry Trends Program
- 3:30 - 5:00 PM**
  - Regions 1-5 Membership Meetings
- 6:00 - 7:00 PM**
  - Gen Jam Reception
- 7:00 - 10:00 PM**
  - Dinner & Entertainment (*Ticket Required*)

### FRIDAY, JULY 31

- 8:00 - 9:30 AM**
  - Registration
- 8:30 - 10:00 AM**
  - ACWA's Hans Doe Past Presidents' Breakfast in Partnership with ACWA JPIA (*Ticket Required*)

### OTHER EVENTS

#### THURSDAY, JULY 30

- 6:45 - 8:30 AM**
  - San Joaquin Valley Agricultural Water Committee

All conference programs are subject to change.



**Beaumont-Cherry Valley Water District  
Regular Board Meeting  
April 8, 2020**

Item 4

STAFF REPORT

**TO:** Board of Directors  
**FROM:** Dan Jagers, General Manager  
**SUBJECT:** **Review and Consider Authorizing the General Manager to Award a Contract to Red Hawk Services, Inc. in an Amount Not to Exceed \$92,566.00 for the Noble Creek Recharge Facility Phase I Fencing Project**

---

**Staff Recommendation**

Consider one of the following alternatives for authorization or provide further direction to District Staff:

**Alternative 1:** Authorize the General Manager to enter into a contract with Red Hawk Services, Inc. for Bid Schedule 1A for an amount not to exceed \$92,566.00 (including 10% contingency) to construct approximately 2,730 linear feet of six-foot high (6') galvanized chain link fencing (with 3 strand barbed wire top finish) at the Noble Creek Recharge Facility Phase 1;

**Alternative 2:** Authorize the General Manager to enter into a contract with Red Hawk Services, Inc. for Bid Schedule 1B for an amount not to exceed \$113,202 (including 10% contingency) to construct approximately 2,730 linear feet of eight-foot high (8') galvanized chain link fencing (with 3 strand barbed wire top finish) at the Noble Creek Recharge Facility Phase 1

**Alternative 3:** Do nothing and allow the Noble Creek Recharge Facility Phase I to remain open to the public and un-fenced.

**Alternative 4:** Provide further direction to District Staff.

**Background**

The Beaumont-Cherry Valley Water District (BCVWD) Board of Directors and District staff have had numerous discussions over a period of two years regarding various options to secure the Noble Creek Recharge Facility Phase 1 (NCRF PH I), an 82-acre facility located on the east side of Beaumont Avenue between Brookside Avenue and Cherry Valley Boulevard. The Phase I area is approximately 28.5 acres of the 82-acre facility. Phase 2 has an existing 6' high chain link fence around said facility.

The Phase I facility was constructed in 2006 and was intended to allow day use with a "community park" purpose. The facility is currently open to the public from sunrise to sunset however, there is currently no fencing around said facility such that the NCRF Phase 1 has 24-hour access to the public via foot traffic.

At its Regular Meeting on March 26, 2020 the Board evaluated the fencing costs and options, and directed staff to provide a review of past fencing options reviewed with the Board of Directors over the project history as well as re-evaluate and analyze potential liability issues related to access of the site, and to obtain a legal opinion regarding same.





Staff has prepared Attachment “A” which provides a summary of various discussions and comments provided by Staff and the Board of Director’s related to the Noble Creek Recharge Facility, Phase 1 Security Item, together with Attachment “B” which provides past Board agenda staff reports and a presentation related to this issue for Board review and reference.

Staff has consulted with Legal Counsel, and Legal Counsel should be ready to provide discussion with the Board at the April 8, 2020 Board Meeting as well as a report regarding liability concerns regarding current public access at the Noble Creek Recharge Facility Phase 1 site.

Over the past few years, Staff has reviewed estimated security fencing option costs with the Board of the following security fencing options **(with various contingencies and soft costs included)** as follows:

1. Chain Link Fence (April 18, 2018 Presentation - Estimated Cost of \$142,700)
2. Wrought Iron (April 18, 2018 Presentation - Estimated Cost of \$629,200)
3. Masonry Block Wall (April 18, 2018 Presentation – Estimated Cost of \$1,109,500)
4. Chain Link Fence (June 7, 2018 Staff Report - Estimated Cost of \$144,160)
5. 6’ Welded Wire Fabric Fence (June 7, 2018 Staff Report - Estimated Cost of \$284,140)
6. 6’ Welded Wire Fabric Fence with Barbed Tape (June 7, 2018 Staff Report - Estimated Cost of \$306,340)
7. 8’ Welded Wire Fabric Fence with Barbed Tape (June 7, 2018 Staff Report - Estimated Cost of \$388,350)
8. And most recently actual bid costs for 6’ and 8’ galvanized, extruded bonded and fusion bonded chain link fence (March 26, 2020 Board Meeting – actual bid costs)

At this time, Staff identifies that we have provided a review of fencing options and feels that the costs previously presented are fair and reasonable and provides an order of magnitude of cost for the Boards review and discussion on this matter.

**Summary**

Fencing

Table 1 below sets forth associated costs for a 6’ high galvanized chain link fence (with 9 gauge chain link fabric) necessary for approval to enter into a contract with Red Hawk Services, Inc. to proceed with fencing installation. Said work includes a 3 strand barbed wire top finish and a 10% contingency.

**Table 1**

<b>Item</b>	<b>Description</b>	<b>Base Amount (Basis of Award)</b>
1A	Base Bid Work (Installation of 6' High Chain Link Fencing, Access Gates, and Appurtenances (with barbed wire)	\$84,150.73
	Contingency (10%)	\$8,415.07
<b>Total Requested Contract Amount</b>		<b>\$92,566.00</b>

Barbed wire top finish is a fencing option requested by some members of the Board of Directors.

MBS



### District Liability

Staff consulted both District Legal Counsel and its liability insurance carrier risk control adviser and will be prepared to provide a verbal report regarding liability as well as legal counsel report during this Staff Report Item for further Board consideration and discussion.

### Fiscal Impact

The fiscal impact to the District for the fencing project will be an amount not to exceed \$92,566.00, as set forth in Table 1. This not-to-exceed amount includes additional funds to provide approximately 10% contingency for construction related costs.

While the Noble Creek Recharge Facility – Phase I Fencing Project is not part of the District's 2020 Operating/Capital Budget, funds are available from the Capital Replacement Reserve budget for completion of this work.

### Attachment(s)

Attachment A – Project Timeline

Attachment B – Previous Project Staff Reports

# ATTACHMENT A - PROJECT TIMELINE

## Beaumont-Cherry Valley Water District Noble Creek Recharge Facility Phase I Fencing Security Strategies

### Summary of Project Timeline and Meeting Comments

Project defined: 2,730 linear feet of fencing and access gates

DATE	MEETING	NOTES OR MINUTES
2020-03-26	Regular Board Item 7	<p><i>Staff recommended contract with Red Hawk Services, Inc. NTE \$92,556 Item tabled.</i></p> <p>Board requested review of project past activity and also a report on liability issues and input from legal counsel.</p> <p>Director Ramirez and Hoffman requested a cost for wrought iron fencing be provided. Mr. Jagers indicated there was a previous review of both wrought iron and concrete masonry block and that a cost estimate should be available for Board review.</p>
2020-02-27	Regular Board GM Report	GM reported that the project is out to bid.
2019-10-09	Regular Board GM Report	GM reported that Bid documents for the Noble Creek Recharge Facility fencing have been prepared, he said. Unfortunately, site complications will restrict fencing to a meandering chain link fence.
2019-05-23	Regular Board Item 5	<p><b>Update: Status of Potential Security Strategies for the Noble Creek Recharge Facility Phase I</b></p> <p>Mr. Jagers explained this has been moving forward slowly. The Request for Proposal is in the final stages.</p> <p>Three to four fencing type options being investigated by staff. Mr. Jagers pointed out that at prior meetings, the coated wire option was of greatest interest to the Board.</p>
2018-12-12	Regular Board Item 13	Director Hoffman encouraged moving forward on the security measures at the Noble creek facility.
2018-10-25	Regular Board Item 6	<p><b>Update: Potential Security Strategies for the Noble Creek Recharge Facility Phase I</b></p> <p>Mr. Jagers identified that the SGPWA is considering using chain link fence and wrought iron at their facility along Beaumont Avenue.</p> <p>Mr. Jagers presented drawings and figures of the welded wire fence panels under consideration and explained detail of the installation. He noted concerns about serviceability over time and suggested waiting to see the outcome of the SGPWA's project.</p> <p>Director Hoffman noted there are a number of District projects that are higher priority and suggested it should be pursued but not on an aggressive basis. President Covington pointed to the options and costs presented previously. He suggested staff obtain estimates on chain link and look at color or coating options with wire across the top.</p>

		<p>President Covington noted that he has observed people in the area at night.</p>
2018-06-28	Regular Board Item 12	<p><b>Update: Status of Potential Security Strategies for the Noble Creek Recharge Facility Phase I</b></p> <p>Staff identified higher priority projects such as well repairs, rate study, grant writing, etc. had moved project status to lower priority.</p> <p>Staff further identified that benches, grills and miscellaneous recreational facilities have been pulled and placed in storage, and staff would be installing signage regarding site access limitations so the public is advised.</p>
2018-06-13	Regular Board Item 9	<p><b>Continued Discussion of Potential Security Strategies for the Noble Creek Recharge Facility Phase I</b></p> <p>Senior Engineer Mark Swanson provided welded wire fence information as requested by the Board at the last Engineering Workshop. Additional estimates for the fencing were also presented for four fencing alternatives including:</p> <ul style="list-style-type: none"> <li>A. 6' Chain Link Fence (w/o contingencies or soft costs) in the amount of \$103,115 (this included one automatic access gate).</li> <li>B. 6' Wireworks Security Fence without barbed wire (w/o contingencies or soft costs) in the amount of \$203,244 (this included one automatic access gate).</li> <li>C. 6' Wireworks Security Fence with barbed tape (w/o contingencies or soft costs) in the amount of \$219,120.22 (this included one automatic access gate).</li> <li>D. 8' Wireworks Security Fence with barbed tape (w/o contingencies or soft costs) in the amount of \$277,785.82 (this included one automatic access gate).</li> </ul> <p>President Covington indicated he is not in favor of the spiral wire fence topper. He noted even a three-strand barbed wire may not be needed and said with the V-topper it may be enough to keep people out. It can be reevaluated if not. He supports the 8 foot height. He noted costs are high, and he offered some suggestions to reduce costs.</p> <p>Mr. Swanson explained the accounting for staff time and effort, and potential survey needs. Mr. Jagers explained the District tries to track all costs and staff time is charged to projects. Mr. Swanson responded to Director Ramirez about attachment of the post caps; he suggested welding. He indicated he favored the 6-ft fence without the Y-bracket. He pointed out that the 8-ft fence is a \$90,000 cost difference.</p> <p>President Covington suggested excluding the barbed wire at \$22,000 making the increase in cost of an 8-ft fence approximately \$80,000. Director Hoffman said he has observed teenagers easily scaling a 6-ft chain link fence; he is leaning toward the taller fence. Director Ramirez noted the wire fence appears more difficult to climb.</p> <p>President Covington asked about the funding source for the fence. Mr. Jagers explained this is an existing facility, but it is still incomplete. The</p>

		<p>fencing would be part of the overall project and could be funded through facilities fees or capital reserve replacement fees.</p> <p>President Covington asked Director Ramirez if he would support an 8-ft fence without barbed wire. Director Ramirez said he understands the safety issues, yet is trying to be as fiscally responsible as possible, and said an \$80,000 to \$90,000 difference means a lot to him. Director Hoffman asked Mr. Jagers about any incidents at Phase II, which is secured by a 6-ft chain link fence. Mr. Jagers said he believes the fence has been cut to gain entry. The wire fencing cannot be patched as easily as chain link.</p> <p>President Covington requested staff to bring back true cost schedules. Director Ramirez requested feedback on vandalism and repairs.</p>
2018-05-31	Special Board Item 3	<p><b>Update on the Discussion of Potential Security Strategies for the Noble Creek Recharge Facility Phase I</b></p> <p>General Manager Jagers provided a review and update. The Board had requested a cost for more aesthetically pleasing fencing, including wire fencing. Preliminary cost estimates were approximately \$384,000, about twice the cost of chain link. Adding razor wire on top increases the cost to approximately \$406,000.</p> <p>Director Diaz stated the barbed wire would not be aesthetically pleasing. Mr. Jagers noted that the Pass Agency is also looking at a strategy for securing their property; he suggested the two agencies potentially coordinate projects. Director Diaz suggested remove the benches and barbecues first to determine if that would alleviate the problem.</p> <p>Director Slawson asked whether the fence would withstand climbing. Assistant Director of Operations James Bean noted that the wire openings are small enough to prevent a foothold in the openings.</p> <p>Mr. Jagers pointed out there are more robust options such as used at correctional facilities, but this fencing is used for railway barriers. Mark Swanson, Senior Engineer, provided additional detail on the fencing. An “anti-climb” option offered is up to \$130 per foot, comparable to block wall costs. Staff also looked at durability. Different colors are also available.</p> <p>Director Ramirez reiterated safety issues and recommended directing staff to share this with the SGPWA and investigating a joint venture. President Covington clarified the consensus of the Board to begin with removal of the picnic benches and barbecues, and directed staff to move forward. The board also agreed no razor wire, but did like the top rail. He requested finalizing this action at the June 13 meeting, and asked staff to provide a cost for the 6 ft. and 8 ft. with top rail, and contrast with 6 ft. chain link. He directed staff to discuss with the SGPWA.</p>
2018-05-09	Regular Board Item 8	<p><b>Consideration of Potential Security Strategies for the Noble Creek Recharge Facility Phase I</b></p> <p>Mr. Jagers introduced the continuing discussion about security. He reminded the Board about the existing situation and reviewed the</p>

		<p>discussion from the Engineering Workshop. The board directed staff to firm up the cost for a chain link option and to provide photos of the facility.</p> <p>Staff sent out typical standard public works chain link specifications and received response from one vendor, which paralleled the staff estimate of \$140,000 for 3,000 feet of fence with three strands of barbed wire at the top.</p> <p>Mr. Jagers reviewed prior discussion, which suggested removal of some of the facilities that may attract undesirable activity. Director Hoffman noted the tables are in good condition and may be able to be used by another entity. Mr. Jagers shared photos of the area and described its layout and uses.</p> <p>President Covington reiterated that the Board agrees that better security is necessary. At the Engineering Workshop, there was consensus on chain link, but it was noted that could be climbed over so it was requested that bids include angled barbed wire to prevent climbing. He noted the staff report includes permanent prohibition of public access, and suggested discussion.</p> <p>President Covington suggested fencing, and allowing daytime public access. If this is the will of the Board, and it turns out to be no better than before, it will be obvious that it must be locked. He indicated apprehension of denying use based on poor behavior by a few.</p> <p>President Covington invited Patsy Reeley for public comment. Ms. Reeley said it is a shame to fence it in. If the picnic area is causing the problem, then get rid of it. She would hate to see a chain link fence.</p> <p>Director Ramirez concurred with Ms. Reeley, and said he is torn although he understands the safety concerns. If the Board decides to move forward, it may make sense to consider a better-looking fence. He suggested having the gates open during the day as a test.</p> <p>Director Diaz asked if it would be possible to locate the fence to secure only the pond area. Mr. Jagers noted from the aspect of security the Board must define limiting access due to safety or because it attracts overnight visitors. Diaz noted safety concerns, and Covington responded that the picnic area is the problem, but he is in favor of securing the entire facility.</p> <p>Director Hoffman noted there is adequate access for equipment, and there are walkways and steps along Beaumont Avenue that would require gates. He pointed out alternative fencing of a powder-coated wire, which is more attractive. He noted that he is leaning toward securing the facility but continuing to allow daytime access. He noted the barbecues are probably not used.</p> <p>Director Ramirez agreed. The District pays attention to its well sites to assure attractive landscape, and believes that the District should continue to take care of its property. He would like to see the alternative fencing. Director Slawson concurred that this need is unfortunate, but he</p>
--	--	---

		<p>believes it should be closed down entirely. He would like to see the other fencing option for both strength / maintenance issues and aesthetics.</p> <p>President Covington requested staff investigate the wire fence and bring samples and photos. He polled the Board members informally about complete closure of the facility: In favor were Directors Slawson and Diaz. President Covington suggested a trial run of keeping the site open during the daytime. If it does not work out, it should be closed. At the end of the day, he said, the District is not in the park business.</p> <p>Mr. Jagers advised that staff would have preliminary costs for discussion at the June Engineering Workshop.</p>
2018-04-18	Special Mtg Item 3	<p><b>Discussion of potential security strategies for the Noble Creek Recharge Facility Phase I</b></p> <p>General Manager Jagers reviewed the Board's desire to address security issues and limit access to the facility after hours. Currently there is no physical restriction to foot traffic. Boulders have been placed to limit vehicle access, but they have been moved. There is a concern regarding adverse risk. Staff was asked to present some options to secure the site.</p> <p>Jagers explained that the facility is located at the northeast corner of Beaumont Avenue and Brookside Avenue. Phase II is secured by a chain link fence and is not accessible by the public. Phase I provides a park-type setting for pedestrian use. Vehicle traffic is restricted at the end of the business day. Day use is allowed for community purposes.</p> <p>Staff proposed three fencing options: chain link, wrought iron, or block wall. The total fencing would be approximately 3,050 feet, and include four or five access gates. There is concern for aesthetics.</p> <p>Jagers shared the cost estimates. The chain link fence could be done in-house, and is the least cost at approximately \$150,000.</p> <p>Director Slawson asked about the existing vinyl fence. Jagers indicated that on the western side the vinyl fence meanders, and a decision would need to be made. Director Hoffman suggested carrying this item to a future meeting. He indicated that the goal of the fencing, security included, should be determined. A six-foot chain link fence is easily climbed. Posting of signs and limiting access may limit the District's risk exposure. Hoffman also noted choices of materials.</p> <p>Covington noted the goals are to limit exposure, limit access and deter criminal elements. He said that although he is concerned about those issues, once a fence is erected he would still like to allow access to pedestrians. He does not want to see a scenario where the District spends the money and vehicles still have access. He said it might be in the District's best interest to remove the barbecues and park benches that encourage undesirable use, but he would like to see it continue to be used as intended. He also suggested a barbed-wire topper for a chain link fence, and preferred fewer gates. He asked staff to consider quality of fencing materials.</p>



		<p>Covington suggested a trial period of allowing pedestrian access with a future report back from staff and if it is not going well the gates can be locked. Director Diaz pointed out the purpose of the facility is for the replenishment ponds, not for the community to enjoy the area. She said it is hazardous and there should not be public access.</p> <p>Jaggers advised that insurance companies generally frown on use of razor wire, as it causes more injuries, but not so much the barbed wire. The last Board opted out of use of such toppers on Phase II, as the look and feel was too like a penitentiary. He noted there are Public Works technical specifications for fencing, which was used on Phase II.</p> <p>Director Slawson asked if The Grange next door is also experiencing problems. He suggested the potential of sharing the cost of overnight security. He said he believes shutting the facility to the public benefits the District from a liability perspective.</p> <p>President Covington asked GM Jaggers to firm up the quotes and agendaize this item for a future meeting. He encouraged the directors to visit the site and be prepared to decide on May 9 whether to continue allowing public access.</p> <p>Covington indicated the landscaping should be maintained for the benefit of the community. All the District's facilities must be up to a standard, as people's homes are nearby. Diaz pointed out she has never seen any water facilities open to public access. Hoffman confirmed that the existing gate would be sufficient for field crew access.</p>
2018-03-14	Regular Board Item 8	<p><b>Discussion: Noble Creek Recharge Facility: Security of Facility; SGPWA Correspondence</b></p> <p>Mr. Jaggers reported that security at the site continues to be a challenge. Rocks have been installed as barriers, but other agencies have installed chain link fencing around ponds. Director Hoffman noted some issues including vandalism. Money, labor and equipment has been invested to make it nice, he said, but it is not as nice as it used to be. He said he agrees with the concern and believes effort should be made to improve.</p> <p>Director Diaz indicated concern about liability; General Manager Jaggers and District Counsel Markman acknowledged the concern. Director Ramirez suggested exploring how to secure the area while allowing some access. President Covington agreed that action is needed and requested options come back to the Board, including options with some opportunity for the public to enjoy the facilities.</p> <p>Mr. Jaggers suggested posting notices on the website and adding a note in bills to alert the public that additional security is being considered. He will bring back options and costs at an Engineering Workshop.</p> <p>Director Diaz stated that the specific purpose of the area is a recharge facility and no one else should be on the property. Director Ramirez also emphasized appearance of the area.</p>



**Beaumont-Cherry Valley Water District  
Special Board Meeting  
April 18, 2018**

Item 3

## STAFF REPORT

**TO:** Board of Directors  
**FROM:** Dan Jagers, General Manager  
**SUBJECT:** Discussion of Potential Security Strategies for the Noble Creek Recharge Facility Phase I

### Staff Recommendation

Direct staff as desired.

### Background

The Noble Creek Recharge Facility, Phase I and Phase 2 is approximately 82 acre site located on the east side of Beaumont Avenue between Cherry Valley Boulevard and Brookside Avenue. Phase I is approximately 28.5 acre and is accessible to the public (vehicle traffic is restricted at the end of every business day) 24 hours a day. Phase 2 is approximately 53.5 acres, consisting of both spreading basins and a 2.0 mg reservoir.

Phase 1 is open to the public from sunrise to sunset. The intent of the BCVWD was to allow day use of the property for community park purposes. The northwest corner of the property is open space, with picnic tables and barbecues. The interior of the recharge facility is also open to vehicle and foot traffic, with pathways among the ponds, more picnic benches, trashcans and a park-like walkway along the edge of Noble Creek.





## **Summary**

During the last few years, both directors and staff have noticed increasing problems with site security, site use, and/or undesirable activity at the Noble Creek facility.

District staff placed large boulders intermittently along the northern edge of the property to help increase site access restrictions after hours, but vehicles are still gaining after-hours entry by moving the boulders.

The Board has asked staff to propose remedies to mitigate the undesirable activity and increase safety at the Recharge Facility Phase I.

Staff believes that some form of fencing or other site restriction may be necessary for this area in order to more securely close the park after hours. Staff recommends use of chain link fencing, wrought iron fencing or possibly block walls. This workshop item presentation will set forth some options that are available to the District and includes handouts that set forth preliminary planning cost estimates for different solutions that might be used. Some areas of concern include site aesthetics considering the setting and the close proximity of the existing white, split rail fencing in place around the ponds.

Gates that allow equipment access and site maintenance will need to be strategically installed and will be operated by staff at park opening and closing times, as is the current procedure.

The northwest triangle of the property is currently unfenced and accessible by vehicle or on foot. New fencing would most likely begin at Point A as shown on Figure 1 located approximately 530 linear feet north of the intersection of Beaumont Avenue and Brookside Avenue, continuing north approximately 2,100 feet to the northeast corner of Beaumont Avenue and Cherry Valley Boulevard, thence eastward to Point B, the existing wrought iron fence enclosing the reservoir, approximately 950 feet to the District's existing wrought iron fence located at the northeast corner of the Phase 1 Recharge Facility, or about 3,050 feet total. (See Figure 1 attached.)



## **Fiscal Impact**

Preliminary options and planning estimates will be presented at the engineering workshop for discussion purposes.

Report prepared by Dan Jaggars, General Manager – April 12, 2018





**Figure 1**  
**Noble Creek Recharge Facility Site Map and Proposed Fence Location**



# Security Strategies for the Noble Creek Recharge Facility

Engineering Workshop  
April 18, 2018



**Beaumont-Cherry Valley Water District**  
Serving the Beaumont, Cherry Valley and some areas of Calimesa

## Background

- ▶ Located on the east side of Beaumont Avenue between Cherry Valley Boulevard and Brookside
- ▶ Phase I:
  - 28.5 acre
  - accessible to the public (vehicle traffic is generally restricted at the end of every business day) 24 hours a day.
- ▶ Phase 2:
  - 53.5 acres of spreading basins
  - 2.0 mg reservoir
  - Public access restricted by existing chain link fencing



## Phase 1 Public Access

- ▶ Day use allowed for community park purposes
- ▶ No restriction on foot traffic
- ▶ Facilities: pathways, picnic benches, trashcans and a park-like walkway along the edge of Noble Creek



## Undesirable Activity Noticed

To address this:

- ▶ Large boulders were placed along the northern edge of the property to restrict vehicle access after hours, but ...
- ▶ Boulders are being moved!



## Proposed Solution

- ▶ Fencing or other site restriction to securely close the Facility after hours
- ▶ Concerns:
  - Aesthetics
  - Proximity of the existing split rail fencing



## Three Possibilities

- ▶ Chain link fencing
- ▶ Wrought iron fencing
- ▶ Block walls

Chain Link



Wrought Iron



Block Wall





## The Proposed Solution: Fence

- ▶ The northwest triangle of the property is currently unfenced and accessible by vehicle or on foot (on foot at all hours)
- ▶ New fencing would total about 3,050 feet



## The Proposed Solution: Gates

- ▶ Allow access only for equipment and site maintenance
- ▶ Operated by staff to restrict public access
- ▶ Estimated need for four vehicle gates
- ▶ Estimated need for five man gates

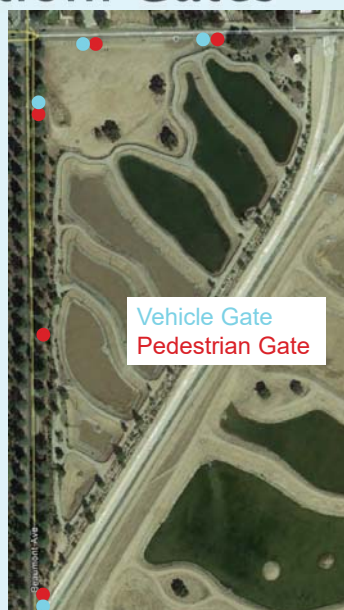

## Cost: Engineer's Estimates

- Chain Link Fence – \$142,700
- Wrought Iron Fence – \$629,200
- Masonry Block Wall – \$1,109,500

Staff requests Board direction.





# ATTACHMENT B

Previously Provided

Beaumont-Cherry Valley Water District  
Special Board Meeting  
May 31, 2018

Item 3

## STAFF REPORT

**TO:** Board of Directors  
**FROM:** Dan Jagers, General Manager  
**SUBJECT:** Update on the Discussion of Potential Security Strategies for the Noble Creek Recharge Facility Phase I

---

### Staff Recommendation

Board discussion and direct staff as desired.

### Background

On April 18, 2018, the District presented a Staff Report with a solution to the lack of security fencing around the Noble Creek Recharge Facility (NCRF), Phase I which is approximately 28.5 acres. The NCRF is located on the east side of Beaumont Avenue between Cherry Valley Boulevard and Brookside Avenue and consists of both spreading basins and trails.

NCRF Phase 1 is currently posted to be open to the public from sunrise to sunset with the intent of allowing public day use of the property for community park purposes, but currently, there is no way to secure the site after hours. The northwest corner of the property is open space, with picnic tables and barbecues. The interior of the recharge facility is also open to District vehicles (maintenance) and public foot traffic; with pathways among the ponds, additional picnic benches, trash cans and a park-like walkway along the edge of Noble Creek.

During the last few years, both directors and staff have noticed increasing problems with site security, site use, and/or undesirable activity at the NCRF. Per the direction of the Board, staff has proposed three (3) potential options for security fencing (chain link, wrought iron, and block wall) to mitigate the undesirable activity and increase safety at the NCRF.

After the April 18 Engineering Workshop, the Board requested that a preliminary construction cost estimate and site photographs be obtained for further discussion of the facility security.

On May 9, 2018, the District presented a slide show and a supplemental staff report which provided preliminary costs for the installation of perimeter chain link fencing. Through Board discussion and at the direction of the Board, staff was requested to evaluate an alternative fence type to provide a more aesthetically pleasing look than chain link. Director Hoffman suggested that Staff look into Welded Wire Fencing (WWF) as has been installed at nearby local areas/facilities.



**Summary**

At the request of the Board, Staff has evaluated WWF<sup>1</sup> as has determined the following:

- Fence panels are available in 4', 5', 6', and 8' heights.
- Fence material is 2"x6" mesh and 6 ga. steel.
- Posts are 2" square and 16 ga.
- Single- and Double-Swing gates
- Single-gate widths are 3.5' to 16' wide.
- Double-gate widths are 7' to 32' wide.
- Steel is galvanized steel, then coated in zinc phosphate, epoxy powder coat, and a polyester color coat.
- 10 year limited warranty.
- Optional Barb-wire Arm Kit or "Y" Bracket for Barb-wire
- Color Options are available.

<sup>1</sup>Wire Works Plus manufactured by Ameristar Fence was evaluated.

**Fiscal Impact**

The below is a preliminary summary of construction costs based on past and recently obtained construction cost information.

<b>Alternative</b>	<b>Type of Fencing</b>	<b>Preliminary Estimated Cost (rounded)</b>
A	6' Chain link	\$144,160
B	6' Welded Wire Fencing	\$284,140
C	6' Welded Wire Fencing (w/ Barbed Tape)	\$306,340

**Attachment(s):**

- Preliminary Cost Estimates
  - Alternative "A" – 6' Chain link
  - Alternative "B" – 6' WWF
  - Alternative "C" – 6' WWF w/ Barbed Tape
- *WireWorks Plus* Information Sheets
- "Y" Bracket Photograph





# BEAUMONT-CHERRY VALLEY WATER DISTRICT

## CHAIN LINK SECURITY FENCE Alternative "A"

### NOBLE CREEK RECHARGE FACILITIES PHASE 1 SECURITY EAST AND NORTH FENCE AND ENTRANCE GATES ENGINEER'S PRELIMINARY ESTIMATE

Item No.	Description	ENGINEER'S ESTIMATE			
		Qty.	Units	Unit Price	Amount
1	Contract bonds, insurance, permits, project management, mobilization of equipment, materials, and labor prior to starting work, and demobilization	1	L.S.	\$ 3,000.00	\$ 3,000.00
2	<b>Site Work</b>				
a.	Chain Link Fence Construction (w/ Barbed Wire)	2,910	L.F.	\$ 26.50	\$ 77,115.00
b.	Drive Access Gate (30 foot wide)	4	L.S.	\$ 1,250.00	\$ 5,000.00
c.	Concrete Gate Runner (2.25' wide x 1' thick x Length)	120	L.F.	\$ 25.00	\$ 3,000.00
d.	Man Access Gate (5 foot wide)	5	L.S.	\$ 500.00	\$ 2,500.00
3	<b>Electrical</b>				
a.	Construct Electrical Gate Operator (One Drive Access Gate - Mechanical)	1	L.S.	\$ 4,000.00	\$ 4,000.00
b.	Gate Opener Electrical (One Drive Access Gate - Mechanical)	1	L.S.	\$ 7,500.00	\$ 7,500.00
4	<b>Misc.</b>				
a.	Start-up and performance testing of all equipment, controls, and instrumentation	1	L.S.	N/A	\$ -
b.	Furnish operation and maintenance manuals for all equipment, controls, and instrumentation	1	L.S.	\$ 1,000.00	\$ 1,000.00
<b>TOTAL ENGINEERS ESTIMATE</b>					<b>\$ 103,115.00</b>
<b>CONTINGENCY</b>				<b>20%</b>	<b>\$20,623.00</b>
<b>TOTAL CONSTRUCTION ESTIMATE AND CONTINGENCIES</b>					<b>\$ 123,738.00</b>

Item No.	Description	ENGINEER'S ESTIMATE			
		Qty.	Units	Unit Price	Amount
1	Engineering	1	L.S.	5.00%	\$ 6,186.90
2	Survey / Mapping	1	L.S.	3.50%	\$ 4,330.83
3	Geotechnical		L.S.	0.00%	\$ -
4	Materials Testing		L.S.	0.00%	\$ -
5	Environmental & Permitting		L.S.	0.00%	\$ -
6	Construction Contract Administration	1	L.S.	3.00%	\$ 3,712.14
7	Inspection	1	L.S.	3.00%	\$ 3,712.14
8	Legal and Administration	1	L.S.	2.00%	\$ 2,474.76
<b>SUBTOTAL OTHER COSTS</b>					<b>\$ 20,416.77</b>
<b>SUBTOTAL COSTRUCTION AND OTHER COSTS</b>					<b>\$ 144,154.77</b>
9	Land, acre				\$ -
<b>TOTAL CONSTRUCTION ESTIMATE AND CONTINGENCIES</b>					<b>\$ 144,154.77</b>

<b>TOTAL CONSTRUCTION ESTIMATE AND CONTINGENCIES (ROUNDED)</b>					<b>\$ 144,160</b>
--	--	--	--	--	-------------------

# BEAUMONT-CHERRY VALLEY WATER DISTRICT

## WIREWORKS<sup>1</sup> SECURITY FENCE

### Alternative "B" - Fencing w/o Barbed Wire

#### NOBLE CREEK RECHARGE FACILITIES PHASE 1 SECURITY EAST AND NORTH FENCE AND ENTRANCE GATES ENGINEER'S PRELIMINARY ESTIMATE

Item No.	Description	ENGINEER'S ESTIMATE			
		Qty.	Units	Unit Price	Amount
1	Contract bonds, insurance, permits, project management, mobilization of equipment, materials, and labor prior to starting work, and demobilization	1	L.S.	\$ 3,000.00	\$ 3,000.00
2	<b>Site Work</b>				
a.	Wireworks Plus 6' Security Fencing (w/ 2" posts)	2,910	L.F.	\$55.84	\$ 162,494.40
b.	Drive Access Gate (20' wide)	4	L.S.	\$ 4,000.00	\$ 16,000.00
c.	Concrete Gate Runner (2.25' wide x 1' thick x Length)	120	L.F.	\$ 25.00	\$ 3,000.00
d.	Man Access Gate (5' wide)	5	L.S.	\$ 1,250.00	\$ 6,250.00
3	<b>Electrical</b>				
a.	Construct Electrical Gate Operator (One Drive Access Gate - Mechanical)	1	L.S.	\$ 4,000.00	\$ 4,000.00
b.	Gate Opener Electrical (One Drive Access Gate - Mechanical)	1	L.S.	\$ 7,500.00	\$ 7,500.00
4	<b>Misc.</b>				
a.	Start-up and performance testing of all equipment, controls, and instrumentation	1	L.S.	N/A	\$ -
b.	Furnish operation and maintenance manuals for all equipment, controls, and instrumentation	1	L.S.	\$ 1,000.00	\$ 1,000.00
<b>TOTAL ENGINEERS ESTIMATE</b>					<b>\$ 203,244.40</b>
<b>CONTINGENCY</b>				20%	<b>\$40,648.88</b>
<b>TOTAL CONSTRUCTION ESTIMATE AND CONTINGENCIES</b>					<b>\$ 243,893.28</b>

Item No.	Description	ENGINEER'S ESTIMATE			
		Qty.	Units	Unit Price	Amount
1	Engineering	1	L.S.	5.00%	\$ 12,194.66
2	Survey / Mapping	1	L.S.	3.50%	\$ 8,536.26
3	Geotechnical		L.S.	0.00%	\$ -
4	Materials Testing		L.S.	0.00%	\$ -
5	Environmental & Permitting		L.S.	0.00%	\$ -
6	Construction Contract Administration	1	L.S.	3.00%	\$ 7,316.80
7	Inspection	1	L.S.	3.00%	\$ 7,316.80
8	Legal and Administration	1	L.S.	2.00%	\$ 4,877.87
<b>SUBTOTAL OTHER COSTS</b>					<b>\$ 40,242.39</b>
<b>SUBTOTAL COSTRUCTION AND OTHER COSTS</b>					<b>\$ 284,135.67</b>
9	Land, acre				\$ -
<b>TOTAL CONSTRUCTION ESTIMATE AND CONTINGENCIES</b>					<b>\$ 284,135.67</b>

<b>TOTAL CONSTRUCTION ESTIMATE AND CONTINGENCIES (ROUNDED)</b>					<b>\$ 284,140</b>
--	--	--	--	--	-------------------

<sup>1</sup> Wireworks is manufactured by Ameristar. This product was pulled for costing purposes only.



# BEAUMONT-CHERRY VALLEY WATER DISTRICT

## WIREWORKS<sup>1</sup> SECURITY FENCE

### Alternative "C" - Fencing with Barbed Tape

NOBLE CREEK RECHARGE FACILITIES PHASE 1 SECURITY EAST AND NORTH FENCE AND ENTRANCE GATES

### ENGINEER'S PRELIMINARY ESTIMATE

Item No.	Description	ENGINEER'S ESTIMATE			
		Qty.	Units	Unit Price	Amount
1	Contract bonds, insurance, permits, project management, mobilization of equipment, materials, and labor prior to starting work, and demobilization	1	L.S.	\$ 3,000.00	\$ 3,000.00
2	<b>Site Work</b>				
a.	Wireworks Plus 6' Security Fencing (w/ 2" posts)	2,910	L.F.	\$55.84	\$ 162,494.40
b.	Barbed Wire "Y" Bracket	375	E.A.	\$21.00	\$ 7,873.32
c.	Barbed Tape	2,910	L.F.	\$2.75	\$ 8,002.50
d.	Drive Access Gate (20' wide)	4	L.S.	\$ 4,000.00	\$ 16,000.00
e.	Concrete Gate Runner (2.25' wide x 1' thick x Length)	120	L.F.	\$ 25.00	\$ 3,000.00
f.	Man Access Gate (5' wide)	5	L.S.	\$ 1,250.00	\$ 6,250.00
3	<b>Electrical</b>				
a.	Construct Electrical Gate Operator (One Drive Access Gate - Mechanical)	1	L.S.	\$ 4,000.00	\$ 4,000.00
b.	Gate Opener Electrical (One Drive Access Gate - Mechanical)	1	L.S.	\$ 7,500.00	\$ 7,500.00
4	<b>Misc.</b>				
a.	Start-up and performance testing of all equipment, controls, and instrumentation	1	L.S.	N/A	\$ -
b.	Furnish operation and maintenance manuals for all equipment, controls, and instrumentation	1	L.S.	\$ 1,000.00	\$ 1,000.00
<b>TOTAL ENGINEERS ESTIMATE</b>					<b>\$ 219,120.22</b>
<b>CONTINGENCY</b>				<b>20%</b>	<b>\$43,824.04</b>
<b>TOTAL CONSTRUCTION ESTIMATE AND CONTINGENCIES</b>					<b>\$ 262,944.26</b>

Item No.	Description	ENGINEER'S ESTIMATE			
		Qty.	Units	Unit Price	Amount
1	Engineering	1	L.S.	5.00%	\$ 13,147.21
2	Survey / Mapping	1	L.S.	3.50%	\$ 9,203.05
3	Geotechnical		L.S.	0.00%	\$ -
4	Materials Testing		L.S.	0.00%	\$ -
5	Environmental & Permitting		L.S.	0.00%	\$ -
6	Construction Contract Administration	1	L.S.	3.00%	\$ 7,888.33
7	Inspection	1	L.S.	3.00%	\$ 7,888.33
8	Legal and Administration	1	L.S.	2.00%	\$ 5,258.89
<b>SUBTOTAL OTHER COSTS</b>					<b>\$ 43,385.80</b>
<b>SUBTOTAL COSTRUCTION AND OTHER COSTS</b>					<b>\$ 306,330.07</b>
9	Land, acre				\$ -
<b>TOTAL CONSTRUCTION ESTIMATE AND CONTINGENCIES</b>					<b>\$ 306,330.07</b>

<b>TOTAL CONSTRUCTION ESTIMATE AND CONTINGENCIES (ROUNDED)</b>					<b>\$ 306,340</b>
--	--	--	--	--	-------------------

<sup>1</sup> Wireworks is manufactured by Ameristar. This product was pulled for costing purposes only.

# WIREWORKS PLUS®



## COMMERCIAL WELDED WIRE STEEL FENCE

The WireWorks Plus fence system is the *new standard in welded wire fencing*. With this product, Ameristar has a fence solution that will reduce dependency on chain link. WireWorks Plus provides *unobstructed visibility, aesthetics, and security* while delivering a *value added fencing solution*.

### PRIMARY APPLICATIONS

- **Commercial Developments**
- **Parking Facilities**
- **Self Storage**
- **Parks & Recreation**
- **Schools & Universities**
- **Apartments (Multi-Family)**
- **Amusement Parks**
- **Healthcare Facilities**



**AMERISTARFENCE.COM | 888-333-3422**

ASSA ABLOY, the global leader in door opening solutions

2020-04-08 - BCVWD Regular Board Meeting - Page 81 of 129

**AMERISTAR®**

**ASSA ABLOY**

# WIREWORKS PLUS<sup>®</sup>

## COMMERCIAL WELDED WIRE STEEL FENCE

6ga WIRE PANELS / 3" V-FOLDS | 2"sq x 16ga & 2.5"sq x 16ga POSTS

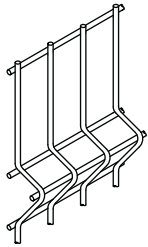

### REINFORCED WELDED WIRE "V" FOLDS





Each WireWorks Plus panel has been designed with a series of architectural "V" folds, vital to the overall reinforcement and strength of the welded wire fence system. These fence panels are fabricated in a pattern of vertical and horizontal wires that are welded at each intersection. The unique design of WireWorks Plus provides strength and stability that is unmatched by typical chain link fence.

### PERMACOAT<sup>™</sup> PROTECTIVE FINISH



Ameristar's production facilities use a state-of-the-art polyester powder coating system that provides a durable and scratch resistant finish. WireWorks Plus is protected with Ameristar's PermaCoat multi-layer coating process. The combination of these layers delivers a system that increases weathering resistance and product durability. The Ameristar coating system results in finished surfaces with unmatched performance.



-  "No-Mar" Polyester Color Coat
-  Epoxy Powder Coat
-  Zinc Phosphate
-  Galvanized Steel



### 10 YEAR LIMITED WARRANTY

The family of WireWorks welded steel fencing products are manufactured from the highest quality materials by skilled craftsmen to meet the highest standards of workmanship in the industry. This is why Ameristar proudly offers a limited 10 year warranty.



FENCE PRODUCTS

TO PLACE YOUR ORDER CALL 888-333-3422 | VISIT [AMERISTARFENCE.COM](http://AMERISTARFENCE.COM)

2020-04-08 - BCVWD Regular Board Meeting - Page 82 of 129

## WIREWORKS PLUS® | 2, 3 & 4 ARCHITECTURAL V-FOLD OPTIONS\*

\*Depending on fence height

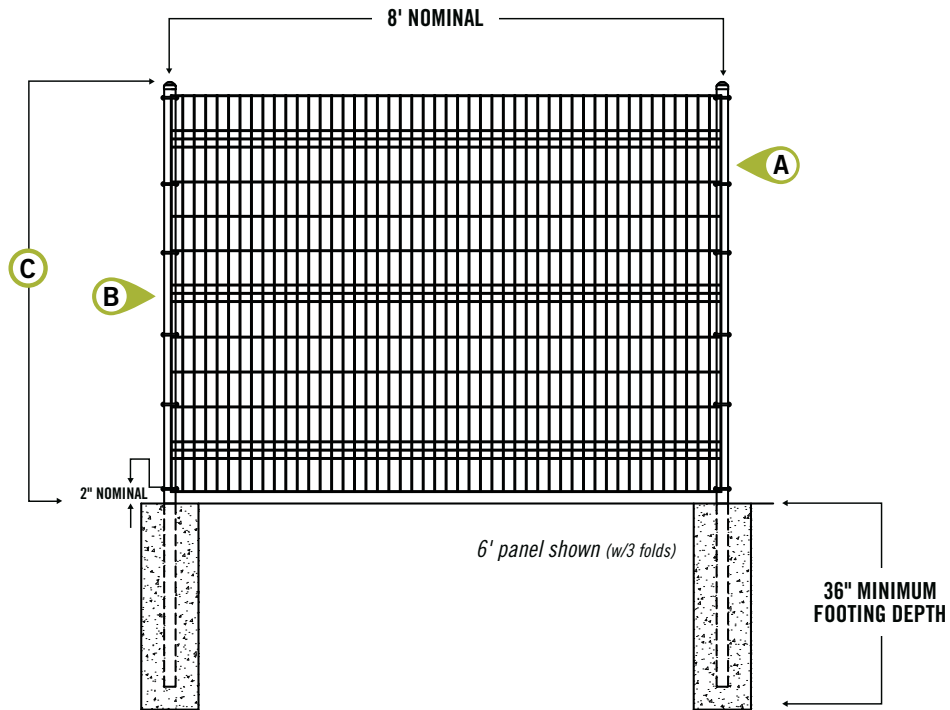

- Ⓐ 2"sq x 16ga / 2.5"sq x 16ga POST OPTIONS
- Ⓑ 2" X 6" MESH / 6ga WIRE
- Ⓒ 2/2/3/4 V-FOLDS (4'/5' /6'/8' heights respectively)
- Ⓓ 4', 5', 6' & 8' PANEL HEIGHT OPTIONS

*Refer to construction specification & tables  
within this section for product details*

Effective: 01/01/18

TO PLACE YOUR ORDER CALL 888-333-3422 | VISIT [AMERISTARFENCE.COM](http://AMERISTARFENCE.COM) |

**AMERISTAR**  
**ASSA ABLOY**

## WIREWORKS PLUS® | V-FOLD PANELS

8' PANEL LENGTH (96" actual width) | 2" w. x 6" h. MESH | 6 GAUGE WIRE

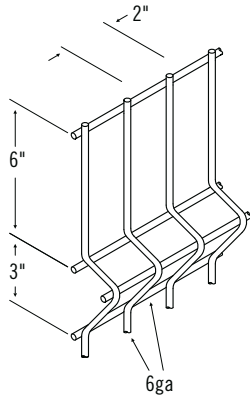

PANEL	ITEM NUMBER	WEIGHT	STOCKING
4'	5WPⓧ0408	30 lbs	⊙
5'	5WPⓧ0508	36 lbs	⊙
6'	5WPⓧ0608	43 lbs	⊙
8'	5WPⓧ0808	59 lbs	⊙

ⓧ = COLOR OPTIONS AVAILABLE | **B** = Black **G** = Green **N** = Bronze **S** = Sand

**TB** = Tube Brown **W** = White

⊙ = NON-STOCKED PRODUCT

For details, see Ameristar's Sales Policy in the catalog guide.

## WIREWORKS PLUS® | V-FOLD BRACKETS

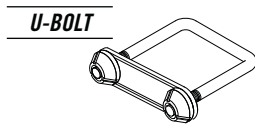

U-BOLT

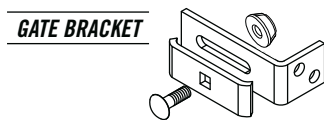

GATE BRACKET



FASTENER SOCKET

DESCRIPTION	SIZE	ITEM NUMBER	BOX QTY	WEIGHT EA	STOCKING
U-BOLT BRACKET FOR LINE / END POST	2"	UBⓧ2R	50	.5 lbs	⊙
	2.5"	UBⓧ25R	50	.8 lbs	⊙
	3"	UBⓧ3R	50	.9 lbs	⊙
	4"	UBⓧ4R	50	.9 lbs	⊙
CORNER / GATE BRACKET	N/A	WⓧGBSR	50	.9 lbs	⊙
FASTENER SOCKET	N/A	6-0058PFG	1	.06 lbs	⊙

ⓧ = COLOR OPTIONS AVAILABLE | **B** = Black **G** = Green **N** = Bronze **S** = Sand

**TB** = Tube Brown **W** = White

⊙ = NON-STOCKED PRODUCT

For details, see Ameristar's Sales Policy in the catalog guide.

Notes: 4' height require (3) brackets per post / 6' height require (5) brackets per post / 8' height require (7) brackets per post.

Effective: 01/01/18

AMERISTAR

ASSA ABLOY

TO PLACE YOUR ORDER CALL 888-333-3422 | VISIT AMERISTARFENCE.COM

## WIREWORKS PLUS® | PANEL ACCESSORIES

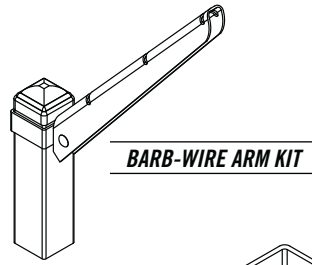

BARB-WIRE ARM KIT

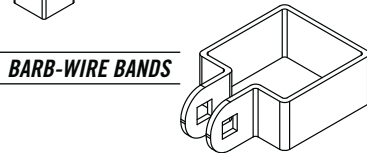

BARB-WIRE BANDS

DESCRIPTION	SIZE	ITEM NUMBER	BAG QTY	WEIGHT EA	STOCKING
BARB-WIRE ARM KIT*	2"	BWAB⊗2	1	---	⊙
	2.5"	BWAB⊗25	1	---	⊙

Each kit includes band, fasteners & barb arm blade.  
 NOTE: Allow 2 inches above panel for barb arm attachment.

BARB-WIRE BANDS**	2"	BWB⊗2R	3	---	⊙
	2.5"	BWB⊗25R	3	3 lbs	⊙

Each bag includes carriage bolts & Tri Groove Security Nuts.  
 NOTE: Allow a minimum of 14 inch post extension above the fence panel for barb-wire attachment.

⊗ = COLOR OPTIONS AVAILABLE | **B** = Black **G** = Green **N** = Bronze **S** = Sand **TB** = Tube Brown  
**W** = White

⊙ = NON-STOCKED PRODUCT  
 For details, see Ameristar's Sales Policy in the catalog guide.

\* Extend end, gate & corner posts to accommodate barb-wire arm attachment.  
 \*\* Use barb-wire bands to attach barb-wire to end, gate & corner posts.

## WIREWORKS PLUS® | CUSTOM FINISHES

WARRANTY ON RAILS CUT VOID WITHOUT PROPER APPLICATION OF ZINC RICH PRIMER & TOUCH-UP PAINT PENS

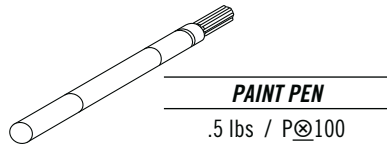

⊗ = COLOR OPTIONS AVAILABLE | **B** = Black **N** = Bronze **W** = White **TB** = Tube Brown **S** = Sand **G** = Green

Effective: 01/01/18

TO PLACE YOUR ORDER CALL 888-333-3422 | VISIT AMERISTARFENCE.COM

AMERISTAR  
 ASSA ABLOY

# WIREWORKS PLUS® | STEEL SQUARE POSTS

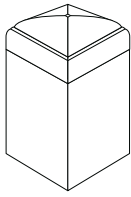

STEEL POSTS

	POST LENGTH	ITEM NUMBER	WEIGHT
2"sq. x 16ga.	6' 9"	WP⊗ 20081	11 lbs
	7' 9"	WP⊗ 20093	13 lbs
	8' 9"	WP⊗ 20105	14 lbs
	10'	WP⊗ 20120	16 lbs
2.5"sq. x 16ga.	11'	WP⊗ 25132	22 lbs
	12'	WP⊗ 25144	24 lbs
2.5"sq. x 12ga.	6'	P⊗ 25072	19 lbs
	7'	P⊗ 25084	22 lbs
	8'	P⊗ 25096	26 lbs
	9'	P⊗ 25108	28 lbs
	10'	P⊗ 25120	31 lbs
	11'	P⊗ 25132	35 lbs
	12'	P⊗ 25144	36 lbs
3"sq. x 12ga.	6'	P⊗ 30072	24 lbs
	7'	P⊗ 30084	30 lbs
	8'	P⊗ 30096	34 lbs
	9'	P⊗ 30108	39 lbs
	10'	P⊗ 30120	43 lbs
	11'	P⊗ 30132	47 lbs
4"sq. x 11 ga.	12'	P⊗ 30144	51 lbs
	6'	P⊗ 40072	39 lbs
	7'	P⊗ 40084	47 lbs
	8'	P⊗ 40096	54 lbs
	9'	P⊗ 40108	61 lbs
	10'	P⊗ 40120	67 lbs
6"sq. x .1875" wall	11'	P⊗ 40132	74 lbs
	12'	P⊗ 40144	81 lbs
	7'	P⊗ 60084	102 lbs
	8'	P⊗ 60096	116 lbs
	9'	P⊗ 60108	131 lbs
	10'	P⊗ 60120	145 lbs
	11'	P⊗ 60132	160 lbs
	12'	P⊗ 60144	174 lbs

⊗ = COLOR OPTIONS AVAILABLE | **B** = Black **G** = Green  
**N** = Bronze **S** = Sand  
**TB** = Tube Brown **W** = White

Effective: 01/01/18

AMERISTAR

ASSA ABLOY

TO PLACE YOUR ORDER CALL 888-333-3422 | VISIT AMERISTARFENCE.COM



## WIREWORKS PLUS® | STEEL PLATED SQUARE POSTS & POST CAPS

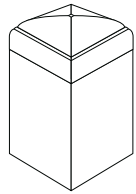

**STEEL POSTS**

	POST LENGTH	PLATE SIZE	ITEM NUMBER	WEIGHT
2.5"sq. x 12ga.	4'	5" sq. x .25" / .5625" holes (8833G)	P⊗ 25048P	16 lbs
	5'	5" sq. x .25" / .5625" holes (8833G)	P⊗ 25060P	19 lbs
	6'	5" sq. x .25" / .5625" holes (8833G)	P⊗ 25072P	22 lbs
	7'	5" sq. x .25" / .5625" holes (8833G)	P⊗ 25084P	26 lbs
	8'	5" sq. x .25" / .5625" holes (8833G)	P⊗ 25096P	28 lbs
	9'	5" sq. x .25" / .5625" holes (8833G)	P⊗ 25108P	31 lbs
3"sq. x 12ga.	10'	5" sq. x .25" / .5625" holes (8833G)	P⊗ 25120P	34 lbs
	4'	6" sq. x .25" / .5625" holes (5003G)	P⊗ 30048P	20 lbs
	5'	6" sq. x .25" / .5625" holes (5003G)	P⊗ 30060P	24 lbs
	6'	6" sq. x .25" / .5625" holes (5003G)	P⊗ 30072P	30 lbs
	7'	6" sq. x .25" / .5625" holes (5003G)	P⊗ 30084P	34 lbs
	8'	6" sq. x .25" / .5625" holes (5003G)	P⊗ 30096P	39 lbs
4"sq. x 11ga.	9'	6" sq. x .25" / .5625" holes (5003G)	P⊗ 30108P	43 lbs
	10'	6" sq. x .25" / .5625" holes (5003G)	P⊗ 30120P	47 lbs
	4'	8" sq. x .375" / .5625" holes (8876G)	P⊗ 40048P	33 lbs
	5'	8" sq. x .375" / .5625" holes (8876G)	P⊗ 40060P	39 lbs
	6'	8" sq. x .375" / .5625" holes (8876G)	P⊗ 40072P	47 lbs
	7'	8" sq. x .375" / .5625" holes (8876G)	P⊗ 40084P	54 lbs
8'	8" sq. x .375" / .5625" holes (8876G)	P⊗ 40096P	61 lbs	
9'	8" sq. x .375" / .5625" holes (8876G)	P⊗ 40108P	67 lbs	
10'	8" sq. x .375" / .5625" holes (8876G)	P⊗ 40120P	74 lbs	

⊗ = COLOR OPTIONS AVAILABLE | **B** = Black **N** = Bronze **S** = Sand **W** = White

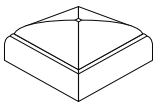

**STANDARD FLAT CAP**

Steel

CAP SIZE	ITEM NUMBER	WEIGHT
2.5"sq.	A⊗ 507	.3 lbs
3"sq.	A⊗ 508	.3 lbs
4"sq.	A⊗ 509	.4 lbs
6"sq.	A⊗ 515	.8 lbs
8"sq.	A⊗ 801	2 lbs

⊗ = COLOR OPTIONS AVAILABLE | **B** = Black **N** = Bronze **S** = Sand **W** = White

Effective: 01/01/18

# WIREWORKS PLUS® | CONSTRUCTION SPECIFICATION 32 31 00

## COMMERCIAL WELDED WIRE ARCHITECTURAL FENCE SYSTEM

### PART 1 - GENERAL

#### 1.01 WORK INCLUDED

The contractor shall provide all labor, materials and appurtenances necessary for installation of the commercial welded wire architectural fence system defined herein at (*specify project site*).

#### 1.02 RELATED WORK

Section \_\_\_\_ - Earthwork

Section \_\_\_\_ - Concrete

#### 1.03 SYSTEM DESCRIPTION

The manufacturer shall supply a total commercial welded wire architectural fence system of the Ameristar® WireWorks Plus® design. The system shall include all components (*i.e., panels, brackets, posts, gates and hardware*) required.

#### 1.04 QUALITY ASSURANCE

The contractor shall provide laborers and supervisors who are thoroughly familiar with the type of construction involved and materials and techniques specified.

#### 1.05 REFERENCES

- **ASTM A653/A653M** – Standard Specification for Steel Sheet, Zinc-Coated (Galvanized) or Zinc-Iron Alloy Coated (Galvannealed) by the Hot-Dip Process
- **ASTM B117** – Practice for Operating Salt-Spray (Fog) Apparatus
- **ASTM D523** – Test Method for Specular Gloss
- **ASTM D714** – Test Method for Evaluating Degree of Blistering in Paint
- **ASTM D1654** – Test Method for Evaluation of Painted or Coated Specimens Subjected to Corrosive Environments
- **ASTM D2244** – Test Method for Calculation of Color Differences from Instrumentally Measured Color Coordinates
- **ASTM D2794** – Test Method for Resistance of Organic Coatings to the Effects of Rapid Deformation (Impact)
- **ASTM D3359** – Test Method for Measuring Adhesion by Tape Test
- **ASTM D6695** – Standard Practice for Xenon-Arc Exposures of Paint and Related Coatings
- **ASTM F2453/F 2453M** – Standard Specification for Welded Wire Mesh Fence Fabric

#### 1.06 SUBMITTAL

The manufacturer's submittal package shall be provided prior to installation.

### 1.07 PRODUCT HANDLING AND STORAGE

Upon receipt at the job site, all materials shall be checked to ensure that no damages occurred during shipping or handling. Materials shall be stored in such a manner to ensure proper ventilation and drainage, and to protect against damage, weather, vandalism and theft.

### PART 2 - MATERIALS

#### 2.01 MANUFACTURER

The fence system shall conform to Ameristar WireWorks Plus design by Ameristar Fence Products, Inc. in Tulsa, Oklahoma.

#### 2.02 MATERIAL

- A.** Steel material for fence posts shall be galvanized prior to forming in accordance with the requirements of **ASTM A653/A653M**, with minimum yield strength of 45,000 psi (310 MPa). The steel shall be hot-dip galvanized to meet the requirements of **ASTM A653/A653M** with a minimum zinc coating weight of 0.60 oz/ft<sup>2</sup>, Coating Designation G-60. Fence posts and gate posts shall meet the minimum size requirements of **Table 1**.
- B.** Steel wire mesh fence panels shall be welded by resistance welding per **ASTM A185** using 6 gauge (0.192") pre-galvanized steel wire, welded at each crossing to form rectangles. Vertical 6ga. (0.192") wires shall be spaced at 2"; horizontal 6ga. (0.192") wires shall be spaced at 6 inches. The cold rolled wire shall have a tensile strength of at least 70,000 PSI and 74,000 PSI weld shear strength. Wire strand shall be galvanized before welded (GBW), .050 ounces per square foot zinc coating conforming to the **ASTM A641**.

#### 2.03 FABRICATION

- A.** Panels and posts shall be precut to specified lengths. Panels shall have a number of structural folds based on the specified panel height as follows:
  1. 48" & 61" height x 96" width panel – 2 horizontal panel folds
  2. 69" height x 96" width panel – 3 horizontal panel folds
  3. 96" height x 96" width panel – 4 horizontal panel folds
- B.** The manufactured panels and posts shall be subjected to an inline electro-deposition coating (E-Coat) process consisting of a multi-stage pretreatment/wash, followed by a duplex application of an epoxy primer and an acrylic topcoat. The minimum cumulative coating thickness of epoxy and acrylic shall be 2 mils (0.058 mm). The color shall be (*specify Black or Bronze*). If color shall be (*specify White, Desert Sand, Green, or Tube Brown*) panels, posts,

Effective: 01/01/18

**AMERISTAR**

**ASSA ABLOY**

| TO PLACE YOUR ORDER CALL 888-333-3422 | VISIT AMERISTARFENCE.COM

## WIREWORKS PLUS® | CONSTRUCTION SPECIFICATION 32 31 00

### COMMERCIAL WELDED WIRE ARCHITECTURAL FENCE SYSTEM

and brackets will undergo Ameristar PermaCoat coating process. The coated panels and posts shall be capable of meeting the performance requirements for each quality characteristic shown in **Table 2**.

- C. Swing gates shall be fabricated using 2" x 12ga square rails and gate ends. Gates that exceed 6' in width will have a 2" sq. x 12ga. intermediate upright. All rail, upright, and gate end intersections shall be joined by welding. Steel gussets (1/4" x 2") shall be welded at each rail to gate end intersection and rail to intermediate intersections (4 gussets per gate bay). Gusset shall be punched to accept gate trussing cable and turnbuckle.

dimensions and gate hardware selected. Type and quantity of gate hinges shall be based on the application; weight, height, and number of gate cycles. The manufacturers' gate drawings shall identify the necessary gate hardware required for the application. Gate hardware shall be provided by the manufacture of the gate and shall be installed per manufacturer's recommendations.

#### 3.05 CLEANING

The contractor shall clean the jobsite of excess materials; post-hole excavations shall be scattered uniformly away from posts.

### PART 3 - EXECUTION

#### 3.01 PREPARATION

All new installation shall be laid out by the contractor in accordance with the construction plans.

#### 3.02 FENCE INSTALLATION

Fence post shall be spaced according to **Table 3**, plus or minus ¼". Fence panels shall be attached to posts with brackets supplied by the manufacturer. Posts shall be set in concrete footers having a minimum depth of 36" (*Note: In some cases, local restrictions of freezing weather conditions may require a greater depth*). The "Earthwork" and "Concrete" sections of this specification shall govern material requirements for the concrete footer. Posts setting by other methods such as plated posts or grouted core-drilled footers are permissible only if shown by engineering analysis to be sufficient in strength for the intended application.

#### 3.03 FENCE INSTALLATION MAINTENANCE

When cutting/drilling rails or posts adhere to the following steps to seal the exposed steel surfaces; 1) Remove all metal shavings from cut area. 2) Apply zinc-rich primer to thoroughly cover cut edge and/or drilled hole; let dry. 3) Apply 2 coats of custom finish paint matching fence color. Failure to seal exposed surfaces per steps 1-3 above will negate warranty. Ameristar spray cans or paint pens shall be used to prime and finish exposed surfaces; it is recommended that paint pens be used to prevent overspray. Use of non-Ameristar parts or components will negate the manufactures' warranty.

#### 3.04 GATE INSTALLATION

Gate posts shall be spaced according to the manufacturers' gate drawings, dependent on standard out-to-out gate leaf

SEE REFERENCED TABLES ON THE FOLLOWING PAGE

Effective: 01/01/18

# WIREWORKS PLUS® | CONSTRUCTION SPECIFICATION 32 31 00

## COMMERCIAL WELDED WIRE ARCHITECTURAL FENCE SYSTEM

**TABLE 1**

MINIMUM SIZES FOR WIREWORKS PLUS POSTS		
FENCE POSTS	PANEL HEIGHTS	
2" x 16 ga.	up to 6' height	
2.5" x 16 ga.	8' height	

GATE LEAF	GATE HEIGHT	
	up to & including 6'	Over 6' and up to 8'
up to 4'	2½" x 12 gauge	3" x 12 gauge
4'1" to 6'	3" x 12 gauge	3" x 12 gauge
6'1" to 10'	4" x 11 gauge	6" x ¾"
10'1" to 16'	6" x ¾"	6" x ¾"

**TABLE 2**

COATING PERFORMANCE REQUIREMENTS		
QUALITY CHARACTERISTICS	ASTM TEST METHOD	PERFORMANCE REQUIREMENTS
ADHESION	D3359 – METHOD B	Adhesion (retention of coating) over 90% of test area (tape and knife kit test).
CORROSION RESISTANCE	B117, D714, D1654	Corrosion resistance over 1,000 hours (scribed per D1654; failure mode is accumulation of 1/8" coating loss from scribe or medium #8 blisters)
IMPACT RESISTANCE	D2794	Impact resistance over 60" lb. (forward impact using 0.625" ball).
WEATHERING RESISTANCE	D822 D2244, D523 (60° method)	Weathering resistance over 1,000 hours (failure mode is 60% loss of gloss or color variance of more than 3 delta-E color units).

**TABLE 3**

WIREWORKS PLUS POST SPACING BY BRACKET TYPE		
SPAN	WIREWORKS PLUS	
POST SIZE	2"	2½"
POST SETTINGS ± ¼" O.C.	96½"	96½"

Effective: 01/01/18

**AMERISTAR**

**ASSA ABLOY**

TO PLACE YOUR ORDER CALL 888-333-3422 | VISIT AMERISTARFENCE.COM

## WIREWORKS PLUS® | LIMITED WARRANTY

### COMMERCIAL WELDED WIRE FENCE

WireWorks Plus® Commercial Welded Wire Architectural Fence System by Ameristar® is manufactured from the highest quality materials by skilled craftsmen to meet the highest standards of workmanship in the industry. Galvanized steel framework shall be subject to a six stage pretreatment/wash followed by an electrostatic spray application of PermaCoat® Color System, a two coat powder system. The base coat is a thermosetting epoxy powder coating (*gray in color*). The top coat is a “no-mar” TGIC polyester powder coat finish, which provides the protection necessary to withstand adverse environmental conditions.

The powder coated surface on all framework (*i.e., panels, posts and brackets*) by Ameristar is guaranteed under normal and proper usage, against cracking, peeling, chipping, blistering or corroding for a period of ten (10) years from the original purchase date. Normal and proper usage does not include physical damage, abrasion or exposure to salty environments to the protective coating.

WireWorks Plus Commercial Welded Wire Architectural Fence System framework is also guaranteed for the same period of time against defects in workmanship or materials.

Should any architectural fence framework manufactured by Ameristar Fence Products fail in accordance with any of the above conditions, Ameristar Fence Products warrants to the original purchaser their redemption through replacement, renewal or issuance of a pro-rated credit. The decision as to which method of redemption is allowed is solely at the discretion of Ameristar. If pro-rated allowance is the chosen alternative, the amount will be based on the total number of years under warranty from date of purchase to date of claim, based on the original cost of framing materials found to be defective. Notice of failure under the conditions of this warranty shall be sent to Ameristar Fence Products or its authorized representative, in writing, together with proof of purchase and shall specify the nature of the defect and when it was first observed. When cutting WireWorks Plus products immediately seal the exposed surfaces by 1) Removing all metal shavings from cut area 2) Apply zinc-rich primer to thoroughly cover cut edge and drilled hole; let dry 3) Apply 2 coats of custom finish paint matching fence color. Failure to seal exposed surfaces per steps 1-3 above will negate warranty. If contractor uses non Ameristar parts/components this will negate the warranty. Should the fence be improperly installed, Ameristar Fence Products shall not be responsible for guaranteed performance or appearance of the material. Neither does this guarantee apply when failure or damage is due to improper use or application, abuse or misuse, salty environments, vandalism or acts of God. Ameristar Fence Products reserves the right to inspect the material to determine validity of the claim.

Upon validation of the claim by Ameristar Fence Products or its authorized representative, redemption by replacement, renewal or issuance of a pro-rated credit shall be made by Ameristar Fence Products. Reimbursement for the costs of removal and installation of materials are not included in the guarantee, nor will Ameristar Fence Products provide those services.

The above constitutes the complete warranty by the manufacturer. No other agreement, written or implied, is valid. Ameristar Fence Products does not authorize any other person or agent to make any other express warranties. Ameristar Fence Products neither assumes nor authorizes any other person or agent to assume any other liability in connection with WireWorks Plus Commercial Welded Wire Architectural Fence System. Some jurisdictions do not allow limitations on how long an implied warranty lasts, nor do they allow an exclusion or limitation of incidental or consequential damages; therefore, the limitations and exclusions noted herein may not apply.

Effective: 01/01/18

# WIREWOKS PLUS® | SINGLE SWING GATE SPECIFICATIONS

2"sq x 12ga GATE ENDS | 2"sq x 12ga RAILS | 2" x 6" x 6ga WELDED WIRE | 3.5' - 16' NOMINAL OPENINGS

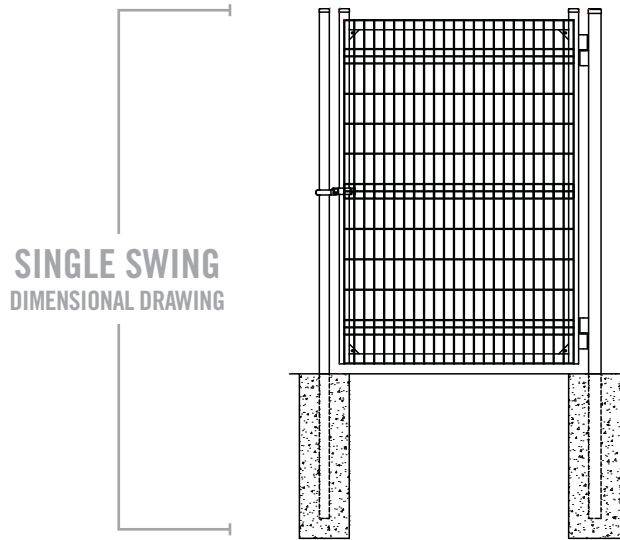

HGBS-25 / HGBS-3  
180 HINGE & STRONG  
ARM LATCH KITS
IGBSX25 / IGBSX3  
BOX HINGE & FORK  
LATCH KITS

OPENING	LEAF WIDTH*	HC	LC	Ps	HC	LC	Ps
3.5'	42"	1.25"	3"	46.25"	2"	2"	46"
4'	48"	1.25"	3"	52.25"	2"	2"	52"
5'	60"	1.25"	3"	64.25"	2"	2"	64"
6'	72"	1.25"	3"	76.25"	2"	2"	76"
7'	84"	1.25"	3"	88.25"	2"	2"	88"
8'	96"	1.25"	3"	100.25"	2"	2"	100"
9'	108"	1.25"	3"	112.25"	2"	2"	112"
10'	120"	1.25"	3"	124.25"	2"	2"	124"
11'	132"	1.25"	3"	136.25"	2"	2"	136"
12'	144"	1.25"	3"	148.25"	2"	2"	148"
13'	156"	1.25"	3"	160.25"	2"	2"	160"
14'	168"	1.25"	3"	172.25"	2"	2"	172"
15'	180"	1.25"	3"	184.25"	2"	2"	184"
16'	192"	1.25"	3"	196.25"	2"	2"	196"

**SINGLE SWING  
HARDWARE KITS & POST  
INTERSPACES**

W = width\* | HC = hinge clearance | LC = latch clearance | Ps = gate post spacing\*\*  
 \* From outside to outside | \*\* From inside to inside

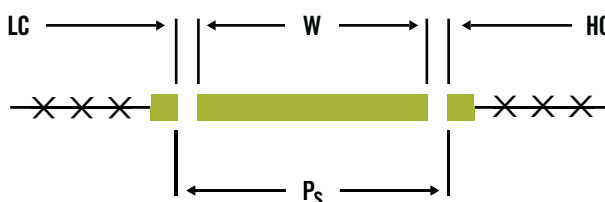

Effective: 01/01/18

# WIREWORKS PLUS® | DOUBLE SWING GATE SPECIFICATIONS

2"sq x 12ga GATE ENDS | 2"sq x 12ga RAILS | 2" x 6" x 6ga WELDED WIRE | 7' - 32' NOMINAL OPENINGS

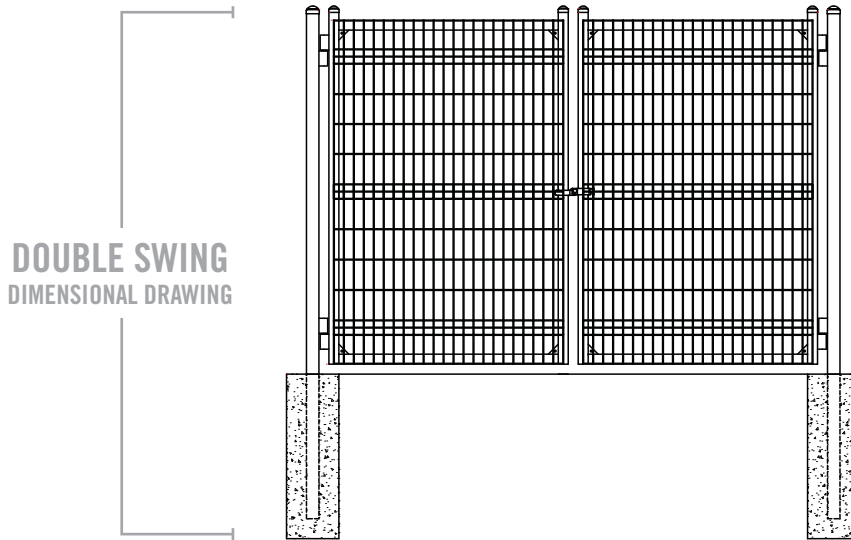

DOUBLE SWING  
DIMENSIONAL DRAWING



DOUBLE SWING  
HARDWARE KITS & POST  
INTERSPACES

OPENING	LEAF WIDTH*	HC	LC	P <sub>d</sub>	HC	LC	P <sub>d</sub>
7'	42"	1.25"	3"	89.5"	2"	2"	90"
8'	48"	1.25"	3"	101.5"	2"	2"	102"
10'	60"	1.25"	3"	125.5"	2"	2"	126"
12'	72"	1.25"	3"	149.5"	2"	2"	150"
14'	84"	1.25"	3"	173.5"	2"	2"	174"
16'	96"	1.25"	3"	197.5"	2"	2"	198"
18'	108"	1.25"	3"	221.5"	2"	2"	222"
20'	120"	1.25"	3"	245.5"	2"	2"	246"
22'	132"	1.25"	3"	269.5"	2"	2"	270"
24'	144"	1.25"	3"	293.5"	2"	2"	294"
26'	156"	1.25"	3"	317.5"	2"	2"	318"
28'	168"	1.25"	3"	341.5"	2"	2"	342"
30'	180"	1.25"	3"	365.5"	2"	2"	366"
32'	192"	1.25"	3"	389.5"	2"	2"	390"

W = width (x2)\* | HC = hinge clearance (x2) | LC = latch clearance  
 P<sub>d</sub> = gate post spacing\*\*

\* From outside to outside | \*\* From inside to inside

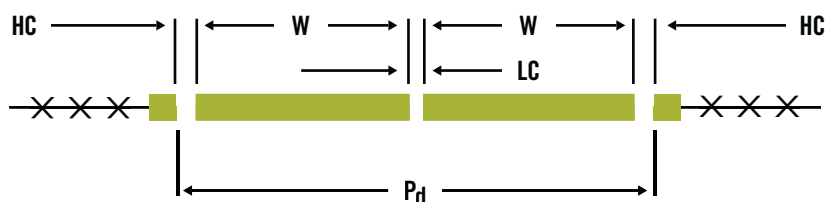

Effective: 01/01/18

TO PLACE YOUR ORDER CALL 888-333-3422 | VISIT AMERISTARFENCE.COM

**AMERISTAR**  
ASSA ABLOY



# WIREWORKS PLUS® | V-FOLD WELDED WIRE GATES

GATE HARDWARE SOLD SEPARATELY

	OPENING	ITEM NUMBER	WEIGHT	STOCKING	
4' HEIGHT	3½'	5WPⓧ04-42	55	ⓧ	
	4'	5WPⓧ04-48	60	ⓧ	
	5'	5WPⓧ04-60	70	ⓧ	
	6'	5WPⓧ04-72	79	ⓧ	
	7'	5WPⓧ04-84	100	ⓧ	
	8'	5WPⓧ04-96	109	ⓧ	
	9'	5WPⓧ04-108	118	ⓧ	
	10'	5WPⓧ04-120	128	ⓧ	
	11'	5WPⓧ04-132	137	ⓧ	
	12'	5WPⓧ04-144	147	ⓧ	
	13'	5WPⓧ04-156	156	ⓧ	
	14'	5WPⓧ04-168	165	ⓧ	
	15'	5WPⓧ04-180	175	ⓧ	
	16'	5WPⓧ04-192	184	ⓧ	
	5' HEIGHT	3½'	5WPⓧ05-42	64	ⓧ
		4'	5WPⓧ05-48	70	ⓧ
5'		5WPⓧ05-60	80	ⓧ	
6'		5WPⓧ05-72	90	ⓧ	
7'		5WPⓧ05-84	115	ⓧ	
8'		5WPⓧ05-96	125	ⓧ	
9'		5WPⓧ05-108	135	ⓧ	
10'		5WPⓧ05-120	146	ⓧ	
11'		5WPⓧ05-132	156	ⓧ	
12'		5WPⓧ05-144	166	ⓧ	
13'		5WPⓧ05-156	177	ⓧ	
14'		5WPⓧ05-168	187	ⓧ	
15'		5WPⓧ05-180	197	ⓧ	
16'		5WPⓧ05-192	208	ⓧ	

ⓧ = COLOR OPTIONS AVAILABLE | **B** = Black **G** = Green **N** = Bronze  
**S** = Sand **TB** = Tube Brown  
**W** = White

ⓧ = NON-STOCKED PRODUCT  
 For details, see Ameristar's Sales Policy in the catalog guide.

Effective: 01/01/18

# WIREWORKS PLUS® | V-FOLD WELDED WIRE GATES

GATE HARDWARE SOLD SEPARATELY

	OPENING	ITEM NUMBER	WEIGHT	STOCKING
6' HEIGHT	3½'	5WP⊗06-42	73	⊗
	4'	5WP⊗06-48	79	⊗
	5'	5WP⊗06-60	90	⊗
	6'	5WP⊗06-72	102	⊗
	7'	5WP⊗06-84	130	⊗
	8'	5WP⊗06-96	141	⊗
	9'	5WP⊗06-108	152	⊗
	10'	5WP⊗06-120	164	⊗
	11'	5WP⊗06-132	175	⊗
	12'	5WP⊗06-144	186	⊗
8' HEIGHT	13'	5WP⊗06-156	197	⊗
	14'	5WP⊗06-168	209	⊗
	15'	5WP⊗06-180	220	⊗
	16'	5WP⊗06-192	231	⊗
	3½'	5WP⊗08-42	88	⊗
	4'	5WP⊗08-48	94	⊗
	5'	5WP⊗08-60	106	⊗
	6'	5WP⊗08-72	118	⊗
	7'	5WP⊗08-84	153	⊗
	8'	5WP⊗08-96	165	⊗
9'	5WP⊗08-108	178	⊗	
10'	5WP⊗08-120	190	⊗	
11'	5WP⊗08-132	202	⊗	
12'	5WP⊗08-144	214	⊗	
13'	5WP⊗08-156	227	⊗	
14'	5WP⊗08-168	239	⊗	
15'	5WP⊗08-180	251	⊗	
16'	5WP⊗08-192	263	⊗	

⊗ = COLOR OPTIONS AVAILABLE | **B** = Black **G** = Green **N** = Bronze  
**S** = Sand **TB** = Tube Brown  
**W** = White

⊙ = NON-STOCKED PRODUCT  
 For details, see Ameristar's Sales Policy in the catalog guide.

Effective: 01/01/18

TO PLACE YOUR ORDER CALL 888-333-3422 | VISIT AMERISTARFENCE.COM

**AMERISTAR**  
**ASSA ABLOY**

*WIREWOKS ANTI-CLIMB®*

*WIREWOKS PLUS®*

*WIREWOKS PLUS®*

*WELDED WIRE STEEL FENCE*

*Effective: 01/01/18*

**AMERISTAR®**  
**ASSA ABLOY**

***TO PLACE YOUR ORDER CALL 888-333-3422 | VISIT AMERISTARFENCE.COM***

2020-04-08 - BCVWD Regular Board Meeting - Page 96 of 129







**Beaumont-Cherry Valley Water District  
Regular Board Meeting  
June 13, 2018**

Item 9

STAFF REPORT

**TO:** Board of Directors  
**FROM:** Dan Jagers, General Manager  
**SUBJECT:** **Continued Discussion of Potential Security Strategies for the Noble Creek Recharge Facility Phase I**

---

**Staff Recommendation**

Board discussion and direct staff as desired.

**Background**

At the April 18, 2018 Board meeting, the District presented a Staff Report with a solution to the lack of security fencing around the Noble Creek Recharge Facility (NCRF), Phase I which is approximately 28.5 acres. The NCRF is located on the east side of Beaumont Avenue between Cherry Valley Boulevard and Brookside Avenue and consists of both spreading basins and trails.

NCRF Phase 1 is currently posted as open to the public from sunrise to sunset with the intent to allow public day use of the property for community park purposes, but currently there is no way to secure the site either after hours or continuously. The northwest corner of the property is currently open space, with picnic tables and barbecues. At this time, the interior of the recharge facility is also open to District vehicles (maintenance) and public foot traffic; with pathways among the ponds, additional picnic benches, trash cans and a park-like walkway along the edge of Noble Creek.

During the last few years, both directors and staff have noticed increasing problems with site security, site use, and/or undesirable activity at the NCRF. Per the direction of the Board, staff has proposed three (3) potential options for security fencing (chain link, wrought iron, and block wall) to mitigate the undesirable activity and increase safety at the NCRF.

After the April 18 meeting, the Board requested that a preliminary construction cost estimate and site photographs be obtained for further discussion of the facility security.

On May 9, 2018, the District presented a slide show and a supplemental staff report which provided preliminary costs for the installation of perimeter chain link fencing. Through Board discussion and at the direction of the Board, staff was requested to evaluate an alternative fence type to provide a more aesthetically pleasing look than chain link. Director Hoffman suggested that Staff look into Welded Wire Fencing (WWF) as has been installed at nearby local areas/facilities.

Upon further discussion during the Engineering Workshop on May 31, 2018, Board had requested Staff to determine preliminary costs for 8-foot high WWF. Staff also identified that the San Gorgonio Pass Water Agency (SGPWA) has begun to discuss security measures for the perimeter of their new recharge facility and Staff was authorized to reach out to SGPWA to



determine if and when they might consider security measures in an effort to more accurately understand local development aesthetic impacts from that activity.

**Summary**

At the request of the Board, Staff has evaluated WWF<sup>1</sup> as has determined the following:

- Fence panels are available in 4’, 5’, 6’, and 8’ heights.
- Fence material is 2”x6” mesh and 6 ga. steel.
- Posts are 2” square and 16 ga (6’ high)
- Posts are 2.5” square x 16 ga. (8’ high)
- Single- and Double-Swing gates
- Single-gate widths are 3.5’ to 16’ wide.
- Double-gate widths are 7’ to 32’ wide.
- Steel is galvanized steel, coated with zinc phosphate, epoxy powder coat, and a polyester color coat.
- 10 year limited warranty.
- Optional Barb-wire Arm Kit or “Y” Bracket for Barb-wire
- Color Options are available: Black, Green, Bronze, Sand, Tube Brown, White

<sup>1</sup>Wire Works Plus manufactured by Ameristar Fence was evaluated.

**Fiscal Impact**

The below is a preliminary summary of engineering estimates of anticipated construction costs based on past and recently obtained construction cost information.

<b>Alternative</b>	<b>Type of Fencing</b>	<b>Preliminary Estimated Cost (rounded)</b>
A	6’ Chain link	\$144,160
B	6’ Welded Wire Fencing	\$284,140
C	6’ Welded Wire Fencing (w/ Barbed Tape)	\$306,340
D	8’ Welded Wire Fencing (w/ Barbed Tape)	\$388,350

**Attachment(s):**

- Preliminary Cost Estimates
  - Alternative “A” – 6’ Chain link
  - Alternative “B” – 6’ WWF
  - Alternative “C” – 6’ WWF w/ Barbed Tape
  - Alternative “D” – 8’ WWF w/ Barbed Tape

**Handout(s):**

- *WireWorks Plus* Information Sheets
- “Y” Bracket Photograph

Report prepared by Mark Swanson, Senior Engineer – June 7, 2018





# BEAUMONT-CHERRY VALLEY WATER DISTRICT

## CHAIN LINK SECURITY FENCE Alternative "A"

### NOBLE CREEK RECHARGE FACILITIES PHASE 1 SECURITY EAST AND NORTH FENCE AND ENTRANCE GATES ENGINEER'S PRELIMINARY ESTIMATE

Item No.	Description	ENGINEER'S ESTIMATE			
		Qty.	Units	Unit Price	Amount
1	Contract bonds, insurance, permits, project management, mobilization of equipment, materials, and labor prior to starting work, and demobilization	1	L.S.	\$ 3,000.00	\$ 3,000.00
2	<b>Site Work</b>				
a.	Chain Link Fence Construction (w/ Barbed Wire)	2,910	L.F.	\$ 26.50	\$ 77,115.00
b.	Drive Access Gate (30 foot wide)	4	L.S.	\$ 1,250.00	\$ 5,000.00
c.	Concrete Gate Runner (2.25' wide x 1' thick x Length)	120	L.F.	\$ 25.00	\$ 3,000.00
d.	Man Access Gate (5 foot wide)	5	L.S.	\$ 500.00	\$ 2,500.00
3	<b>Electrical</b>				
a.	Construct Electrical Gate Operator (One Drive Access Gate - Mechanical)	1	L.S.	\$ 4,000.00	\$ 4,000.00
b.	Gate Opener Electrical (One Drive Access Gate - Mechanical)	1	L.S.	\$ 7,500.00	\$ 7,500.00
4	<b>Misc.</b>				
a.	Start-up and performance testing of all equipment, controls, and instrumentation	1	L.S.	N/A	\$ -
b.	Furnish operation and maintenance manuals for all equipment, controls, and instrumentation	1	L.S.	\$ 1,000.00	\$ 1,000.00
<b>TOTAL ENGINEERS ESTIMATE</b>					<b>\$ 103,115.00</b>
<b>CONTINGENCY</b>					<b>20%</b>
<b>TOTAL CONSTRUCTION ESTIMATE AND CONTINGENCIES</b>					<b>\$ 123,738.00</b>

Item No.	Description	ENGINEER'S ESTIMATE			
		Qty.	Units	Unit Price	Amount
1	Engineering	1	L.S.	5.00%	\$ 6,186.90
2	Survey / Mapping	1	L.S.	3.50%	\$ 4,330.83
3	Geotechnical		L.S.	0.00%	\$ -
4	Materials Testing		L.S.	0.00%	\$ -
5	Environmental & Permitting		L.S.	0.00%	\$ -
6	Construction Contract Administration	1	L.S.	3.00%	\$ 3,712.14
7	Inspection	1	L.S.	3.00%	\$ 3,712.14
8	Legal and Administration	1	L.S.	2.00%	\$ 2,474.76
<b>SUBTOTAL OTHER COSTS</b>					<b>\$ 20,416.77</b>
<b>SUBTOTAL COSTRUCTION AND OTHER COSTS</b>					<b>\$ 144,154.77</b>
9	Land, acre				\$ -
<b>TOTAL CONSTRUCTION ESTIMATE AND CONTINGENCIES</b>					<b>\$ 144,154.77</b>

<b>TOTAL CONSTRUCTION ESTIMATE AND CONTINGENCIES (ROUNDED)</b>					<b>\$ 144,160</b>
--	--	--	--	--	-------------------

# BEAUMONT-CHERRY VALLEY WATER DISTRICT

## WIREWOKS<sup>1</sup> SECURITY FENCE

### Alternative "B" - 6' Fencing w/o Barbed Wire

#### NOBLE CREEK RECHARGE FACILITIES PHASE 1 SECURITY EAST AND NORTH FENCE AND ENTRANCE GATES ENGINEER'S PRELIMINARY ESTIMATE

Item No.	Description	ENGINEER'S ESTIMATE			
		Qty.	Units	Unit Price	Amount
1	Contract bonds, insurance, permits, project management, mobilization of equipment, materials, and labor prior to starting work, and demobilization	1	L.S.	\$ 3,000.00	\$ 3,000.00
2	<b>Site Work</b>				
a.	Wireworks Plus 6' Security Fencing (w/ 2" posts)	2,910	L.F.	\$55.84	\$ 162,494.40
b.	Drive Access Gate (20' wide)	4	L.S.	\$ 4,000.00	\$ 16,000.00
c.	Concrete Gate Runner (2.25' wide x 1' thick x Length)	120	L.F.	\$ 25.00	\$ 3,000.00
d.	Man Access Gate (5' wide)	5	L.S.	\$ 1,250.00	\$ 6,250.00
3	<b>Electrical</b>				
a.	Construct Electrical Gate Operator (One Drive Access Gate - Mechanical)	1	L.S.	\$ 4,000.00	\$ 4,000.00
b.	Gate Opener Electrical (One Drive Access Gate - Mechanical)	1	L.S.	\$ 7,500.00	\$ 7,500.00
4	<b>Misc.</b>				
a.	Start-up and performance testing of all equipment, controls, and instrumentation	1	L.S.	N/A	\$ -
b.	Furnish operation and maintenance manuals for all equipment, controls, and instrumentation	1	L.S.	\$ 1,000.00	\$ 1,000.00
<b>TOTAL ENGINEERS ESTIMATE</b>					<b>\$ 203,244.40</b>
<b>CONTINGENCY</b>					<b>20%</b>
<b>TOTAL CONSTRUCTION ESTIMATE AND CONTINGENCIES</b>					<b>\$ 243,893.28</b>

Item No.	Description	ENGINEER'S ESTIMATE			
		Qty.	Units	Unit Price	Amount
1	Engineering	1	L.S.	5.00%	\$ 12,194.66
2	Survey / Mapping	1	L.S.	3.50%	\$ 8,536.26
3	Geotechnical		L.S.	0.00%	\$ -
4	Materials Testing		L.S.	0.00%	\$ -
5	Environmental & Permitting		L.S.	0.00%	\$ -
6	Construction Contract Administration	1	L.S.	3.00%	\$ 7,316.80
7	Inspection	1	L.S.	3.00%	\$ 7,316.80
8	Legal and Administration	1	L.S.	2.00%	\$ 4,877.87
<b>SUBTOTAL OTHER COSTS</b>					<b>\$ 40,242.39</b>
<b>SUBTOTAL COSTRUCTION AND OTHER COSTS</b>					<b>\$ 284,135.67</b>
9	Land, acre				\$ -
<b>TOTAL CONSTRUCTION ESTIMATE AND CONTINGENCIES</b>					<b>\$ 284,135.67</b>

<b>TOTAL CONSTRUCTION ESTIMATE AND CONTINGENCIES (ROUNDED)</b>					<b>\$ 284,140</b>
--	--	--	--	--	-------------------

<sup>1</sup> Wireworks is manufactured by Ameristar. This product was pulled for costing purposes only.

# BEAUMONT-CHERRY VALLEY WATER DISTRICT

## WIREWORKS<sup>1</sup> SECURITY FENCE

### Alternative "C" - 6' Fencing with Barbed Tape

#### NOBLE CREEK RECHARGE FACILITIES PHASE 1 SECURITY EAST AND NORTH FENCE AND ENTRANCE GATES ENGINEER'S PRELIMINARY ESTIMATE

Item No.	Description	ENGINEER'S ESTIMATE			
		Qty.	Units	Unit Price	Amount
1	Contract bonds, insurance, permits, project management, mobilization of equipment, materials, and labor prior to starting work, and demobilization	1	L.S.	\$ 3,000.00	\$ 3,000.00
2	<b>Site Work</b>				
a.	Wireworks Plus 6' Security Fencing (w/ 2" posts)	2,910	L.F.	\$55.84	\$ 162,494.40
b.	Barbed Wire "Y" Bracket	375	E.A.	\$21.00	\$ 7,873.32
c.	Barbed Tape	2,910	L.F.	\$2.75	\$ 8,002.50
d.	Drive Access Gate (20' wide)	4	L.S.	\$ 4,000.00	\$ 16,000.00
e.	Concrete Gate Runner (2.25' wide x 1' thick x Length)	120	L.F.	\$ 25.00	\$ 3,000.00
f.	Man Access Gate (5' wide)	5	L.S.	\$ 1,250.00	\$ 6,250.00
3	<b>Electrical</b>				
a.	Construct Electrical Gate Operator (One Drive Access Gate - Mechanical)	1	L.S.	\$ 4,000.00	\$ 4,000.00
b.	Gate Opener Electrical (One Drive Access Gate - Mechanical)	1	L.S.	\$ 7,500.00	\$ 7,500.00
4	<b>Misc.</b>				
a.	Start-up and performance testing of all equipment, controls, and instrumentation	1	L.S.	N/A	\$ -
b.	Furnish operation and maintenance manuals for all equipment, controls, and instrumentation	1	L.S.	\$ 1,000.00	\$ 1,000.00
<b>TOTAL ENGINEERS ESTIMATE</b>					<b>\$ 219,120.22</b>
<b>CONTINGENCY</b>				<b>20%</b>	<b>\$43,824.04</b>
<b>TOTAL CONSTRUCTION ESTIMATE AND CONTINGENCIES</b>					<b>\$ 262,944.26</b>

Item No.	Description	ENGINEER'S ESTIMATE			
		Qty.	Units	Unit Price	Amount
1	Engineering	1	L.S.	5.00%	\$ 13,147.21
2	Survey / Mapping	1	L.S.	3.50%	\$ 9,203.05
3	Geotechnical		L.S.	0.00%	\$ -
4	Materials Testing		L.S.	0.00%	\$ -
5	Environmental & Permitting		L.S.	0.00%	\$ -
6	Construction Contract Administration	1	L.S.	3.00%	\$ 7,888.33
7	Inspection	1	L.S.	3.00%	\$ 7,888.33
8	Legal and Administration	1	L.S.	2.00%	\$ 5,258.89
<b>SUBTOTAL OTHER COSTS</b>					<b>\$ 43,385.80</b>
<b>SUBTOTAL COSTRUCTION AND OTHER COSTS</b>					<b>\$ 306,330.07</b>
9	Land, acre				\$ -
<b>TOTAL CONSTRUCTION ESTIMATE AND CONTINGENCIES</b>					<b>\$ 306,330.07</b>

<b>TOTAL CONSTRUCTION ESTIMATE AND CONTINGENCIES (ROUNDED)</b>					<b>\$ 306,340</b>
--	--	--	--	--	-------------------

<sup>1</sup> Wireworks is manufactured by Ameristar. This product was pulled for costing purposes only.

# BEAUMONT-CHERRY VALLEY WATER DISTRICT

## WIREWORKS<sup>1</sup> SECURITY FENCE

### Alternative "D" - 8' Fencing w/ Barbed Wire

#### NOBLE CREEK RECHARGE FACILITIES PHASE 1 SECURITY EAST AND NORTH FENCE AND ENTRANCE GATES

#### ENGINEER'S PRELIMINARY ESTIMATE

Item No.	Description	ENGINEER'S ESTIMATE			
		Qty.	Units	Unit Price	Amount
1	Contract bonds, insurance, permits, project management, mobilization of equipment, materials, and labor prior to starting work, and demobilization	1	L.S.	\$ 3,000.00	\$ 3,000.00
2	<b>Site Work</b>				
a.	Wireworks Plus 8' Security Fencing (w/ 2.5" posts)	2,910	L.F.	\$76.00	\$ 221,160.00
b.	Barbed Wire "Y" Bracket	375	E.A.	\$21.00	\$ 7,873.32
c.	Barbed Tape	2,910	L.F.	\$2.75	\$ 8,002.50
d.	Drive Access Gate (20' wide)	4	L.S.	\$ 4,000.00	\$ 16,000.00
e.	Concrete Gate Runner (2.25' wide x 1' thick x Length)	120	L.F.	\$ 25.00	\$ 3,000.00
f.	Man Access Gate (5' wide)	5	L.S.	\$ 1,250.00	\$ 6,250.00
3	<b>Electrical</b>				
a.	Construct Electrical Gate Operator (One Drive Access Gate - Mechanical)	1	L.S.	\$ 4,000.00	\$ 4,000.00
b.	Gate Opener Electrical (One Drive Access Gate - Mechanical)	1	L.S.	\$ 7,500.00	\$ 7,500.00
4	<b>Misc.</b>				
a.	Start-up and performance testing of all equipment, controls, and instrumentation	1	L.S.	N/A	\$ -
b.	Furnish operation and maintenance manuals for all equipment, controls, and instrumentation	1	L.S.	\$ 1,000.00	\$ 1,000.00
<b>TOTAL ENGINEERS ESTIMATE</b>					<b>\$ 277,785.82</b>
<b>CONTINGENCY</b>				<b>20%</b>	<b>\$55,557.16</b>
<b>TOTAL CONSTRUCTION ESTIMATE AND CONTINGENCIES</b>					<b>\$ 333,342.98</b>

Item No.	Description	ENGINEER'S ESTIMATE			
		Qty.	Units	Unit Price	Amount
1	Engineering	1	L.S.	5.00%	\$ 16,667.15
2	Survey / Mapping	1	L.S.	3.50%	\$ 11,667.00
3	Geotechnical		L.S.	0.00%	\$ -
4	Materials Testing		L.S.	0.00%	\$ -
5	Environmental & Permitting		L.S.	0.00%	\$ -
6	Construction Contract Administration	1	L.S.	3.00%	\$ 10,000.29
7	Inspection	1	L.S.	3.00%	\$ 10,000.29
8	Legal and Administration	1	L.S.	2.00%	\$ 6,666.86
<b>SUBTOTAL OTHER COSTS</b>					<b>\$ 55,001.59</b>
<b>SUBTOTAL COSTRUCTION AND OTHER COSTS</b>					<b>\$ 388,344.58</b>
9	Land, acre				\$ -
<b>TOTAL CONSTRUCTION ESTIMATE AND CONTINGENCIES</b>					<b>\$ 388,344.58</b>

<b>TOTAL CONSTRUCTION ESTIMATE AND CONTINGENCIES (ROUNDED)</b>					<b>\$ 388,350</b>
--	--	--	--	--	-------------------

<sup>1</sup> Wireworks is manufactured by Ameristar. This product was pulled for costing purposes only.



# WIREWORKS PLUS®



## COMMERCIAL WELDED WIRE STEEL FENCE

The WireWorks Plus fence system is the *new standard in welded wire fencing*. With this product, Ameristar has a fence solution that will reduce dependency on chain link. WireWorks Plus provides *unobstructed visibility, aesthetics, and security* while delivering a *value added fencing solution*.

### PRIMARY APPLICATIONS

- **Commercial Developments**
- **Parking Facilities**
- **Self Storage**
- **Parks & Recreation**
- **Schools & Universities**
- **Apartments (Multi-Family)**
- **Amusement Parks**
- **Healthcare Facilities**



FENCE PRODUCTS

[AMERISTARFENCE.COM](http://AMERISTARFENCE.COM) | 888-333-3422

ASSA ABLOY, the global leader in door opening solutions

2020-04-08 - BCVWD Regular Board Meeting - Page 105 of 129

**AMERISTAR®**

**ASSA ABLOY**



# WIREWORKS PLUS<sup>®</sup>

## COMMERCIAL WELDED WIRE STEEL FENCE

6ga WIRE PANELS / 3" V-FOLDS | 2"sq x 16ga & 2.5"sq x 16ga POSTS

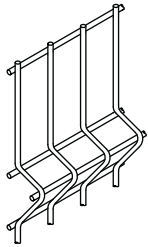

### REINFORCED WELDED WIRE "V" FOLDS





Each WireWorks Plus panel has been designed with a series of architectural "V" folds, vital to the overall reinforcement and strength of the welded wire fence system. These fence panels are fabricated in a pattern of vertical and horizontal wires that are welded at each intersection. The unique design of WireWorks Plus provides strength and stability that is unmatched by typical chain link fence.

### PERMACOAT<sup>™</sup> PROTECTIVE FINISH



Ameristar's production facilities use a state-of-the-art polyester powder coating system that provides a durable and scratch resistant finish. WireWorks Plus is protected with Ameristar's PermaCoat multi-layer coating process. The combination of these layers delivers a system that increases weathering resistance and product durability. The Ameristar coating system results in finished surfaces with unmatched performance.



-  "No-Mar" Polyester Color Coat
-  Epoxy Powder Coat
-  Zinc Phosphate
-  Galvanized Steel



### 10 YEAR LIMITED WARRANTY

The family of WireWorks welded steel fencing products are manufactured from the highest quality materials by skilled craftsmen to meet the highest standards of workmanship in the industry. This is why Ameristar proudly offers a limited 10 year warranty.



FENCE PRODUCTS

TO PLACE YOUR ORDER CALL 888-333-3422 | VISIT [AMERISTARFENCE.COM](http://AMERISTARFENCE.COM)

2020-04-08 - BCVWD Regular Board Meeting - Page 106 of 129

## WIREWORKS PLUS® | 2, 3 & 4 ARCHITECTURAL V-FOLD OPTIONS\*

\*Depending on fence height

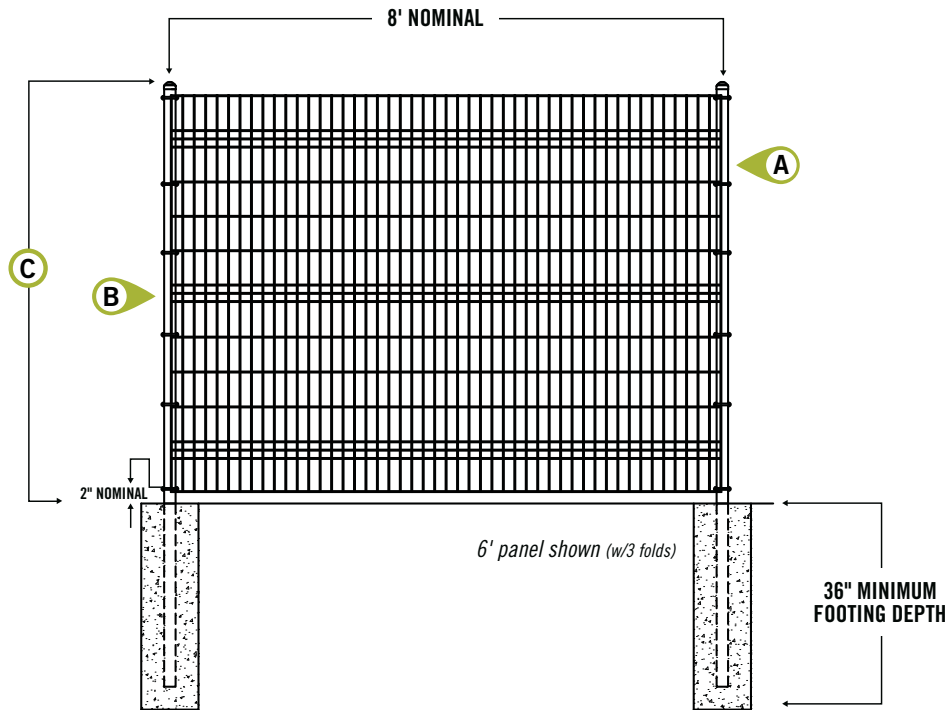

- A 2"sq x 16ga / 2.5"sq x 16ga POST OPTIONS
- B 2" X 6" MESH / 6ga WIRE
- C 2/2/3/4 V-FOLDS (4'/5' /6'/8' heights respectively)
- D 4', 5', 6' & 8' PANEL HEIGHT OPTIONS

*Refer to construction specification & tables  
 within this section for product details*

Effective: 01/01/18

TO PLACE YOUR ORDER CALL 888-333-3422 | VISIT AMERISTARFENCE.COM

AMERISTAR  
 ASSA ABLOY

## WIREWOKS PLUS® | V-FOLD PANELS

8' PANEL LENGTH (96" actual width) | 2" w. x 6" h. MESH | 6 GAUGE WIRE

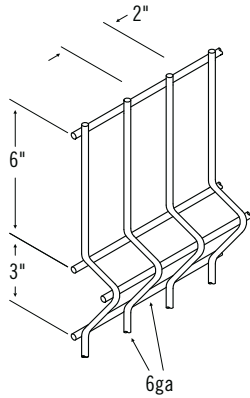

PANEL	ITEM NUMBER	WEIGHT	STOCKING
4'	5WP⊗0408	30 lbs	⊙
5'	5WP⊗0508	36 lbs	⊙
6'	5WP⊗0608	43 lbs	⊙
8'	5WP⊗0808	59 lbs	⊙

⊗ = COLOR OPTIONS AVAILABLE | **B** = Black **G** = Green **N** = Bronze **S** = Sand

**TB** = Tube Brown **W** = White

⊙ = NON-STOCKED PRODUCT

For details, see Ameristar's Sales Policy in the catalog guide.

## WIREWOKS PLUS® | V-FOLD BRACKETS

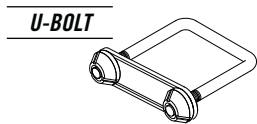

U-BOLT

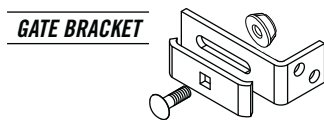

GATE BRACKET



FASTENER SOCKET

DESCRIPTION	SIZE	ITEM NUMBER	BOX QTY	WEIGHT EA	STOCKING
U-BOLT BRACKET FOR LINE / END POST	2"	UB⊗2R	50	.5 lbs	⊙
	2.5"	UB⊗25R	50	.8 lbs	⊙
	3"	UB⊗3R	50	.9 lbs	⊙
	4"	UB⊗4R	50	.9 lbs	⊙
CORNER / GATE BRACKET	N/A	W⊗GBSR	50	.9 lbs	⊙
FASTENER SOCKET	N/A	6-0058PFG	1	.06 lbs	⊙

⊗ = COLOR OPTIONS AVAILABLE | **B** = Black **G** = Green **N** = Bronze **S** = Sand

**TB** = Tube Brown **W** = White

⊙ = NON-STOCKED PRODUCT

For details, see Ameristar's Sales Policy in the catalog guide.

Notes: 4' height require (3) brackets per post / 6' height require (5) brackets per post / 8' height require (7) brackets per post.

Effective: 01/01/18

AMERISTAR

ASSA ABLOY

TO PLACE YOUR ORDER CALL 888-333-3422 | VISIT AMERISTARFENCE.COM

## WIREWORKS PLUS® | PANEL ACCESSORIES

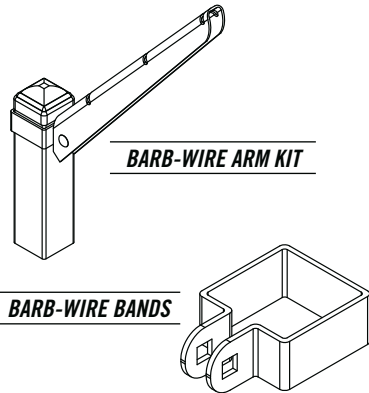

DESCRIPTION	SIZE	ITEM NUMBER	BAG QTY	WEIGHT EA	STOCKING
BARB-WIRE ARM KIT*	2"	BWAB⊗2	1	---	⊗
	2.5"	BWAB⊗25	1	---	⊗

Each kit includes band, fasteners & barb arm blade.  
 NOTE: Allow 2 inches above panel for barb arm attachment.

BARB-WIRE BANDS**	2"	BWB⊗2R	3	---	⊗
	2.5"	BWB⊗25R	3	3 lbs	⊗

Each bag includes carriage bolts & Tri Groove Security Nuts.  
 NOTE: Allow a minimum of 14 inch post extension above the fence panel for barb-wire attachment.

⊗ = COLOR OPTIONS AVAILABLE | **B** = Black **G** = Green **N** = Bronze **S** = Sand **TB** = Tube Brown  
**W** = White

⊗ = NON-STOCKED PRODUCT  
 For details, see Ameristar's Sales Policy in the catalog guide.

\* Extend end, gate & corner posts to accommodate barb-wire arm attachment.  
 \*\* Use barb-wire bands to attach barb-wire to end, gate & corner posts.

## WIREWORKS PLUS® | CUSTOM FINISHES

WARRANTY ON RAILS CUT VOID WITHOUT PROPER APPLICATION OF ZINC RICH PRIMER & TOUCH-UP PAINT PENS

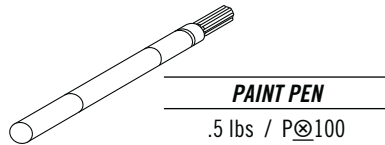

PAINT PEN

.5 lbs / P⊗100



ZINC-RICH PAINT PEN

.5 lbs / PZ100

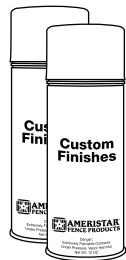

SPRAY PAINT

1.1 lbs / F⊗100

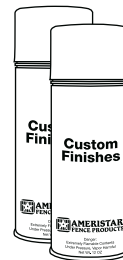

ZINC-RICH PRIMER

1.1 lbs / FZ100

⊗ = COLOR OPTIONS AVAILABLE | **B** = Black **N** = Bronze **W** = White **TB** = Tube Brown **S** = Sand **G** = Green

Effective: 01/01/18

TO PLACE YOUR ORDER CALL 888-333-3422 | VISIT AMERISTARFENCE.COM

AMERISTAR  
 ASSA ABLOY

# WIREWORKS PLUS® | STEEL SQUARE POSTS

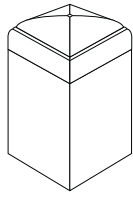

STEEL POSTS

	POST LENGTH	ITEM NUMBER	WEIGHT
2"sq. x 16ga.	6' 9"	WP⊗ 20081	11 lbs
	7' 9"	WP⊗ 20093	13 lbs
	8' 9"	WP⊗ 20105	14 lbs
	10'	WP⊗ 20120	16 lbs
2.5"sq. x 16ga.	11'	WP⊗ 25132	22 lbs
	12'	WP⊗ 25144	24 lbs
2.5"sq. x 12ga.	6'	P⊗ 25072	19 lbs
	7'	P⊗ 25084	22 lbs
	8'	P⊗ 25096	26 lbs
	9'	P⊗ 25108	28 lbs
	10'	P⊗ 25120	31 lbs
	11'	P⊗ 25132	35 lbs
	12'	P⊗ 25144	36 lbs
3"sq. x 12ga.	6'	P⊗ 30072	24 lbs
	7'	P⊗ 30084	30 lbs
	8'	P⊗ 30096	34 lbs
	9'	P⊗ 30108	39 lbs
	10'	P⊗ 30120	43 lbs
	11'	P⊗ 30132	47 lbs
4"sq. x 11 ga.	12'	P⊗ 30144	51 lbs
	6'	P⊗ 40072	39 lbs
	7'	P⊗ 40084	47 lbs
	8'	P⊗ 40096	54 lbs
	9'	P⊗ 40108	61 lbs
	10'	P⊗ 40120	67 lbs
6"sq. x .1875" wall	11'	P⊗ 40132	74 lbs
	12'	P⊗ 40144	81 lbs
	7'	P⊗ 60084	102 lbs
	8'	P⊗ 60096	116 lbs
	9'	P⊗ 60108	131 lbs
	10'	P⊗ 60120	145 lbs
	11'	P⊗ 60132	160 lbs
	12'	P⊗ 60144	174 lbs

⊗ = COLOR OPTIONS AVAILABLE | **B** = Black **G** = Green  
**N** = Bronze **S** = Sand  
**TB** = Tube Brown **W** = White

Effective: 01/01/18

AMERISTAR

ASSA ABLOY

TO PLACE YOUR ORDER CALL 888-333-3422 | VISIT AMERISTARFENCE.COM

## WIREWORKS PLUS® | STEEL PLATED SQUARE POSTS & POST CAPS

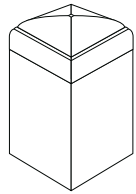

**STEEL POSTS**

	POST LENGTH	PLATE SIZE	ITEM NUMBER	WEIGHT
2.5"sq. x 12ga.	4'	5" sq. x .25" / .5625" holes (8833G)	P⊗ 25048P	16 lbs
	5'	5" sq. x .25" / .5625" holes (8833G)	P⊗ 25060P	19 lbs
	6'	5" sq. x .25" / .5625" holes (8833G)	P⊗ 25072P	22 lbs
	7'	5" sq. x .25" / .5625" holes (8833G)	P⊗ 25084P	26 lbs
	8'	5" sq. x .25" / .5625" holes (8833G)	P⊗ 25096P	28 lbs
	9'	5" sq. x .25" / .5625" holes (8833G)	P⊗ 25108P	31 lbs
3"sq. x 12ga.	10'	5" sq. x .25" / .5625" holes (8833G)	P⊗ 25120P	34 lbs
	4'	6" sq. x .25" / .5625" holes (5003G)	P⊗ 30048P	20 lbs
	5'	6" sq. x .25" / .5625" holes (5003G)	P⊗ 30060P	24 lbs
	6'	6" sq. x .25" / .5625" holes (5003G)	P⊗ 30072P	30 lbs
	7'	6" sq. x .25" / .5625" holes (5003G)	P⊗ 30084P	34 lbs
	8'	6" sq. x .25" / .5625" holes (5003G)	P⊗ 30096P	39 lbs
4"sq. x 11ga.	9'	6" sq. x .25" / .5625" holes (5003G)	P⊗ 30108P	43 lbs
	10'	6" sq. x .25" / .5625" holes (5003G)	P⊗ 30120P	47 lbs
	4'	8" sq. x .375" / .5625" holes (8876G)	P⊗ 40048P	33 lbs
	5'	8" sq. x .375" / .5625" holes (8876G)	P⊗ 40060P	39 lbs
	6'	8" sq. x .375" / .5625" holes (8876G)	P⊗ 40072P	47 lbs
	7'	8" sq. x .375" / .5625" holes (8876G)	P⊗ 40084P	54 lbs
8'	8" sq. x .375" / .5625" holes (8876G)	P⊗ 40096P	61 lbs	
9'	8" sq. x .375" / .5625" holes (8876G)	P⊗ 40108P	67 lbs	
10'	8" sq. x .375" / .5625" holes (8876G)	P⊗ 40120P	74 lbs	

⊗ = COLOR OPTIONS AVAILABLE | **B** = Black **N** = Bronze **S** = Sand **W** = White

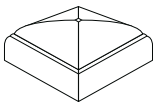

**STANDARD FLAT CAP**

Steel

CAP SIZE	ITEM NUMBER	WEIGHT
2.5"sq.	A⊗ 507	.3 lbs
3"sq.	A⊗ 508	.3 lbs
4"sq.	A⊗ 509	.4 lbs
6"sq.	A⊗ 515	.8 lbs
8"sq.	A⊗ 801	2 lbs

⊗ = COLOR OPTIONS AVAILABLE | **B** = Black **N** = Bronze **S** = Sand **W** = White

Effective: 01/01/18



**WIREWORKS PLUS® | CONSTRUCTION SPECIFICATION 32 31 00****COMMERCIAL WELDED WIRE ARCHITECTURAL FENCE SYSTEM****PART 1 - GENERAL****1.01 WORK INCLUDED**

The contractor shall provide all labor, materials and appurtenances necessary for installation of the commercial welded wire architectural fence system defined herein at (*specify project site*).

**1.02 RELATED WORK**

Section \_\_\_\_ - Earthwork

Section \_\_\_\_ - Concrete

**1.03 SYSTEM DESCRIPTION**

The manufacturer shall supply a total commercial welded wire architectural fence system of the Ameristar® WireWorks Plus® design. The system shall include all components (*i.e., panels, brackets, posts, gates and hardware*) required.

**1.04 QUALITY ASSURANCE**

The contractor shall provide laborers and supervisors who are thoroughly familiar with the type of construction involved and materials and techniques specified.

**1.05 REFERENCES**

- **ASTM A653/A653M** – Standard Specification for Steel Sheet, Zinc-Coated (Galvanized) or Zinc-Iron Alloy Coated (Galvannealed) by the Hot-Dip Process
- **ASTM B117** – Practice for Operating Salt-Spray (Fog) Apparatus
- **ASTM D523** – Test Method for Specular Gloss
- **ASTM D714** – Test Method for Evaluating Degree of Blistering in Paint
- **ASTM D1654** – Test Method for Evaluation of Painted or Coated Specimens Subjected to Corrosive Environments
- **ASTM D2244** – Test Method for Calculation of Color Differences from Instrumentally Measured Color Coordinates
- **ASTM D2794** – Test Method for Resistance of Organic Coatings to the Effects of Rapid Deformation (Impact)
- **ASTM D3359** – Test Method for Measuring Adhesion by Tape Test
- **ASTM D6695** – Standard Practice for Xenon-Arc Exposures of Paint and Related Coatings
- **ASTM F2453/F 2453M** – Standard Specification for Welded Wire Mesh Fence Fabric

**1.06 SUBMITTAL**

The manufacturer's submittal package shall be provided prior to installation.

**1.07 PRODUCT HANDLING AND STORAGE**

Upon receipt at the job site, all materials shall be checked to ensure that no damages occurred during shipping or handling. Materials shall be stored in such a manner to ensure proper ventilation and drainage, and to protect against damage, weather, vandalism and theft.

**PART 2 - MATERIALS****2.01 MANUFACTURER**

The fence system shall conform to Ameristar WireWorks Plus design by Ameristar Fence Products, Inc. in Tulsa, Oklahoma.

**2.02 MATERIAL**

- A.** Steel material for fence posts shall be galvanized prior to forming in accordance with the requirements of **ASTM A653/A653M**, with minimum yield strength of 45,000 psi (310 MPa). The steel shall be hot-dip galvanized to meet the requirements of **ASTM A653/A653M** with a minimum zinc coating weight of 0.60 oz/ft<sup>2</sup>, Coating Designation G-60. Fence posts and gate posts shall meet the minimum size requirements of **Table 1**.
- B.** Steel wire mesh fence panels shall be welded by resistance welding per **ASTM A185** using 6 gauge (0.192") pre-galvanized steel wire, welded at each crossing to form rectangles. Vertical 6ga. (0.192") wires shall be spaced at 2"; horizontal 6ga. (0.192") wires shall be spaced at 6 inches. The cold rolled wire shall have a tensile strength of at least 70,000 PSI and 74,000 PSI weld shear strength. Wire strand shall be galvanized before welded (GBW), .050 ounces per square foot zinc coating conforming to the **ASTM A641**.

**2.03 FABRICATION**

- A.** Panels and posts shall be precut to specified lengths. Panels shall have a number of structural folds based on the specified panel height as follows:
  1. 48" & 61" height x 96" width panel – 2 horizontal panel folds
  2. 69" height x 96" width panel – 3 horizontal panel folds
  3. 96" height x 96" width panel – 4 horizontal panel folds
- B.** The manufactured panels and posts shall be subjected to an inline electro-deposition coating (E-Coat) process consisting of a multi-stage pretreatment/wash, followed by a duplex application of an epoxy primer and an acrylic topcoat. The minimum cumulative coating thickness of epoxy and acrylic shall be 2 mils (0.058 mm). The color shall be (*specify Black or Bronze*). If color shall be (*specify White, Desert Sand, Green, or Tube Brown*) panels, posts,

Effective: 01/01/18

**AMERISTAR**

**ASSA ABLOY**

| **TO PLACE YOUR ORDER CALL 888-333-3422** | **VISIT AMERISTARFENCE.COM**

## WIREWORKS PLUS® | CONSTRUCTION SPECIFICATION 32 31 00

### COMMERCIAL WELDED WIRE ARCHITECTURAL FENCE SYSTEM

and brackets will undergo Ameristar PermaCoat coating process. The coated panels and posts shall be capable of meeting the performance requirements for each quality characteristic shown in **Table 2**.

- C. Swing gates shall be fabricated using 2" x 12ga square rails and gate ends. Gates that exceed 6' in width will have a 2" sq. x 12ga. intermediate upright. All rail, upright, and gate end intersections shall be joined by welding. Steel gussets (1/4" x 2") shall be welded at each rail to gate end intersection and rail to intermediate intersections (4 gussets per gate bay). Gusset shall be punched to accept gate trussing cable and turnbuckle.

dimensions and gate hardware selected. Type and quantity of gate hinges shall be based on the application; weight, height, and number of gate cycles. The manufacturers' gate drawings shall identify the necessary gate hardware required for the application. Gate hardware shall be provided by the manufacture of the gate and shall be installed per manufacturer's recommendations.

#### 3.05 CLEANING

The contractor shall clean the jobsite of excess materials; post-hole excavations shall be scattered uniformly away from posts.

### PART 3 - EXECUTION

#### 3.01 PREPARATION

All new installation shall be laid out by the contractor in accordance with the construction plans.

#### 3.02 FENCE INSTALLATION

Fence post shall be spaced according to **Table 3**, plus or minus ¼". Fence panels shall be attached to posts with brackets supplied by the manufacturer. Posts shall be set in concrete footers having a minimum depth of 36" (*Note: In some cases, local restrictions of freezing weather conditions may require a greater depth*). The "Earthwork" and "Concrete" sections of this specification shall govern material requirements for the concrete footer. Posts setting by other methods such as plated posts or grouted core-drilled footers are permissible only if shown by engineering analysis to be sufficient in strength for the intended application.

#### 3.03 FENCE INSTALLATION MAINTENANCE

When cutting/drilling rails or posts adhere to the following steps to seal the exposed steel surfaces; 1) Remove all metal shavings from cut area. 2) Apply zinc-rich primer to thoroughly cover cut edge and/or drilled hole; let dry. 3) Apply 2 coats of custom finish paint matching fence color. Failure to seal exposed surfaces per steps 1-3 above will negate warranty. Ameristar spray cans or paint pens shall be used to prime and finish exposed surfaces; it is recommended that paint pens be used to prevent overspray. Use of non-Ameristar parts or components will negate the manufactures' warranty.

#### 3.04 GATE INSTALLATION

Gate posts shall be spaced according to the manufacturers' gate drawings, dependent on standard out-to-out gate leaf

SEE REFERENCED TABLES ON THE FOLLOWING PAGE

Effective: 01/01/18

# WIREWORKS PLUS® | CONSTRUCTION SPECIFICATION 32 31 00

## COMMERCIAL WELDED WIRE ARCHITECTURAL FENCE SYSTEM

**TABLE 1**

MINIMUM SIZES FOR WIREWORKS PLUS POSTS		
FENCE POSTS	PANEL HEIGHTS	
2" x 16 ga.	up to 6' height	
2.5" x 16 ga.	8' height	

GATE LEAF	GATE HEIGHT	
	up to & including 6'	Over 6' and up to 8'
up to 4'	2½" x 12 gauge	3" x 12 gauge
4'1" to 6'	3" x 12 gauge	3" x 12 gauge
6'1" to 10'	4" x 11 gauge	6" x ¾"
10'1" to 16'	6" x ¾"	6" x ¾"

**TABLE 2**

COATING PERFORMANCE REQUIREMENTS		
QUALITY CHARACTERISTICS	ASTM TEST METHOD	PERFORMANCE REQUIREMENTS
ADHESION	D3359 – METHOD B	Adhesion ( <i>retention of coating</i> ) over 90% of test area ( <i>tape and knife kit test</i> ).
CORROSION RESISTANCE	B117, D714, D1654	Corrosion resistance over 1,000 hours ( <i>scribed per D1654; failure mode is accumulation of 1/8" coating loss from scribe or medium #8 blisters</i> )
IMPACT RESISTANCE	D2794	Impact resistance over 60" lb. ( <i>forward impact using 0.625" ball</i> ).
WEATHERING RESISTANCE	D822 D2244, D523 (60° method)	Weathering resistance over 1,000 hours ( <i>failure mode is 60% loss of gloss or color variance of more than 3 delta-E color units</i> ).

**TABLE 3**

WIREWORKS PLUS POST SPACING BY BRACKET TYPE		
SPAN	WIREWORKS PLUS	
POST SIZE	2"	2½"
POST SETTINGS ± ¼" O.C.	96½"	96½"

Effective: 01/01/18

**AMERISTAR**

**ASSA ABLOY**

TO PLACE YOUR ORDER CALL 888-333-3422 | VISIT [AMERISTARFENCE.COM](http://AMERISTARFENCE.COM)

## WIREWORKS PLUS® | LIMITED WARRANTY

### COMMERCIAL WELDED WIRE FENCE

WireWorks Plus® Commercial Welded Wire Architectural Fence System by Ameristar® is manufactured from the highest quality materials by skilled craftsmen to meet the highest standards of workmanship in the industry. Galvanized steel framework shall be subject to a six stage pretreatment/wash followed by an electrostatic spray application of PermaCoat® Color System, a two coat powder system. The base coat is a thermosetting epoxy powder coating (*gray in color*). The top coat is a “no-mar” TGIC polyester powder coat finish, which provides the protection necessary to withstand adverse environmental conditions.

The powder coated surface on all framework (*i.e., panels, posts and brackets*) by Ameristar is guaranteed under normal and proper usage, against cracking, peeling, chipping, blistering or corroding for a period of ten (10) years from the original purchase date. Normal and proper usage does not include physical damage, abrasion or exposure to salty environments to the protective coating.

WireWorks Plus Commercial Welded Wire Architectural Fence System framework is also guaranteed for the same period of time against defects in workmanship or materials.

Should any architectural fence framework manufactured by Ameristar Fence Products fail in accordance with any of the above conditions, Ameristar Fence Products warrants to the original purchaser their redemption through replacement, renewal or issuance of a pro-rated credit. The decision as to which method of redemption is allowed is solely at the discretion of Ameristar. If pro-rated allowance is the chosen alternative, the amount will be based on the total number of years under warranty from date of purchase to date of claim, based on the original cost of framing materials found to be defective. Notice of failure under the conditions of this warranty shall be sent to Ameristar Fence Products or its authorized representative, in writing, together with proof of purchase and shall specify the nature of the defect and when it was first observed. When cutting WireWorks Plus products immediately seal the exposed surfaces by 1) Removing all metal shavings from cut area 2) Apply zinc-rich primer to thoroughly cover cut edge and drilled hole; let dry 3) Apply 2 coats of custom finish paint matching fence color. Failure to seal exposed surfaces per steps 1-3 above will negate warranty. If contractor uses non Ameristar parts/components this will negate the warranty. Should the fence be improperly installed, Ameristar Fence Products shall not be responsible for guaranteed performance or appearance of the material. Neither does this guarantee apply when failure or damage is due to improper use or application, abuse or misuse, salty environments, vandalism or acts of God. Ameristar Fence Products reserves the right to inspect the material to determine validity of the claim.

Upon validation of the claim by Ameristar Fence Products or its authorized representative, redemption by replacement, renewal or issuance of a pro-rated credit shall be made by Ameristar Fence Products. Reimbursement for the costs of removal and installation of materials are not included in the guarantee, nor will Ameristar Fence Products provide those services.

The above constitutes the complete warranty by the manufacturer. No other agreement, written or implied, is valid. Ameristar Fence Products does not authorize any other person or agent to make any other express warranties. Ameristar Fence Products neither assumes nor authorizes any other person or agent to assume any other liability in connection with WireWorks Plus Commercial Welded Wire Architectural Fence System. Some jurisdictions do not allow limitations on how long an implied warranty lasts, nor do they allow an exclusion or limitation of incidental or consequential damages; therefore, the limitations and exclusions noted herein may not apply.

Effective: 01/01/18

# WIREWOKS PLUS® | SINGLE SWING GATE SPECIFICATIONS

2"sq x 12ga GATE ENDS | 2"sq x 12ga RAILS | 2" x 6" x 6ga WELDED WIRE | 3.5' - 16' NOMINAL OPENINGS

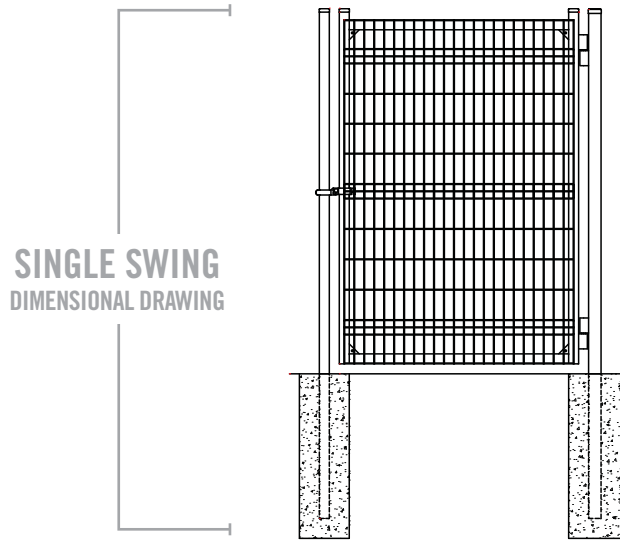

HGBS-25 / HGBS-3  
180 HINGE & STRONG  
ARM LATCH KITS
IGBSX25 / IGBSX3  
BOX HINGE & FORK  
LATCH KITS

OPENING	LEAF WIDTH*	HC	LC	Ps	HC	LC	Ps
3.5'	42"	1.25"	3"	46.25"	2"	2"	46"
4'	48"	1.25"	3"	52.25"	2"	2"	52"
5'	60"	1.25"	3"	64.25"	2"	2"	64"
6'	72"	1.25"	3"	76.25"	2"	2"	76"
7'	84"	1.25"	3"	88.25"	2"	2"	88"
8'	96"	1.25"	3"	100.25"	2"	2"	100"
9'	108"	1.25"	3"	112.25"	2"	2"	112"
10'	120"	1.25"	3"	124.25"	2"	2"	124"
11'	132"	1.25"	3"	136.25"	2"	2"	136"
12'	144"	1.25"	3"	148.25"	2"	2"	148"
13'	156"	1.25"	3"	160.25"	2"	2"	160"
14'	168"	1.25"	3"	172.25"	2"	2"	172"
15'	180"	1.25"	3"	184.25"	2"	2"	184"
16'	192"	1.25"	3"	196.25"	2"	2"	196"

**SINGLE SWING  
HARDWARE KITS & POST  
INTERSPACES**

W = width\* | HC = hinge clearance | LC = latch clearance | Ps = gate post spacing\*\*  
 \* From outside to outside | \*\* From inside to inside

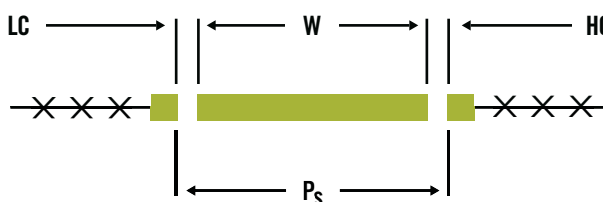

Effective: 01/01/18

**AMERISTAR**  
ASSA ABLOY

TO PLACE YOUR ORDER CALL 888-333-3422 | VISIT AMERISTARFENCE.COM

# WIREWORKS PLUS® | DOUBLE SWING GATE SPECIFICATIONS

2"sq x 12ga GATE ENDS | 2"sq x 12ga RAILS | 2" x 6" x 6ga WELDED WIRE | 7' - 32' NOMINAL OPENINGS

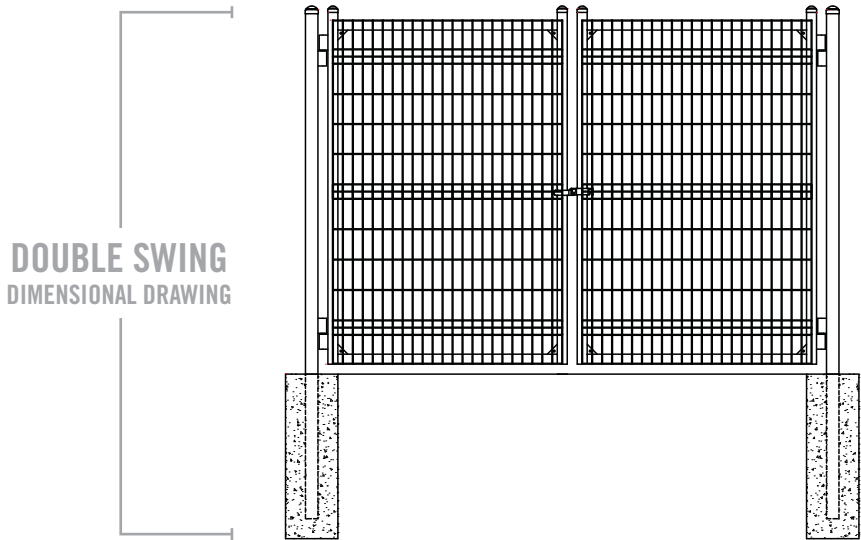

HGBD  
180 HINGE & STRONG  
ARM LATCH KIT
IGBDX  
BOX HINGE & FORK  
LATCH KIT

OPENING	LEAF WIDTH*	HC	LC	P <sub>d</sub>	HC	LC	P <sub>d</sub>
7'	42"	1.25"	3"	89.5"	2"	2"	90"
8'	48"	1.25"	3"	101.5"	2"	2"	102"
10'	60"	1.25"	3"	125.5"	2"	2"	126"
12'	72"	1.25"	3"	149.5"	2"	2"	150"
14'	84"	1.25"	3"	173.5"	2"	2"	174"
16'	96"	1.25"	3"	197.5"	2"	2"	198"
18'	108"	1.25"	3"	221.5"	2"	2"	222"
20'	120"	1.25"	3"	245.5"	2"	2"	246"
22'	132"	1.25"	3"	269.5"	2"	2"	270"
24'	144"	1.25"	3"	293.5"	2"	2"	294"
26'	156"	1.25"	3"	317.5"	2"	2"	318"
28'	168"	1.25"	3"	341.5"	2"	2"	342"
30'	180"	1.25"	3"	365.5"	2"	2"	366"
32'	192"	1.25"	3"	389.5"	2"	2"	390"

DOUBLE SWING  
HARDWARE KITS & POST  
INTERSPACES

W = width (x2)\* | HC = hinge clearance (x2) | LC = latch clearance  
 P<sub>d</sub> = gate post spacing\*\*  
 \* From outside to outside | \*\* From inside to inside

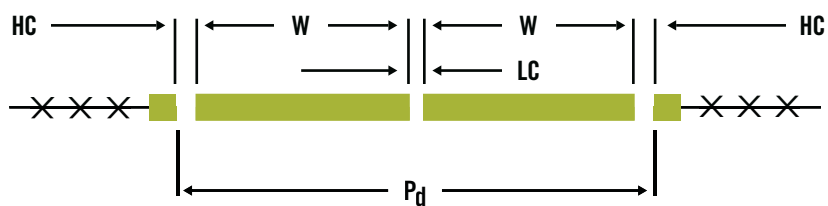

Effective: 01/01/18

TO PLACE YOUR ORDER CALL 888-333-3422 | VISIT AMERISTARFENCE.COM | **AMERISTAR**  
 ASSA ABLOY



# WIREWORKS PLUS® | V-FOLD WELDED WIRE GATES

GATE HARDWARE SOLD SEPARATELY

	OPENING	ITEM NUMBER	WEIGHT	STOCKING	
4' HEIGHT	3½'	5WPⓧ04-42	55	⊗	
	4'	5WPⓧ04-48	60	⊗	
	5'	5WPⓧ04-60	70	⊗	
	6'	5WPⓧ04-72	79	⊗	
	7'	5WPⓧ04-84	100	⊗	
	8'	5WPⓧ04-96	109	⊗	
	9'	5WPⓧ04-108	118	⊗	
	10'	5WPⓧ04-120	128	⊗	
	11'	5WPⓧ04-132	137	⊗	
	12'	5WPⓧ04-144	147	⊗	
	13'	5WPⓧ04-156	156	⊗	
	14'	5WPⓧ04-168	165	⊗	
	15'	5WPⓧ04-180	175	⊗	
	16'	5WPⓧ04-192	184	⊗	
	5' HEIGHT	3½'	5WPⓧ05-42	64	⊗
		4'	5WPⓧ05-48	70	⊗
5'		5WPⓧ05-60	80	⊗	
6'		5WPⓧ05-72	90	⊗	
7'		5WPⓧ05-84	115	⊗	
8'		5WPⓧ05-96	125	⊗	
9'		5WPⓧ05-108	135	⊗	
10'		5WPⓧ05-120	146	⊗	
11'		5WPⓧ05-132	156	⊗	
12'		5WPⓧ05-144	166	⊗	
13'		5WPⓧ05-156	177	⊗	
14'		5WPⓧ05-168	187	⊗	
15'		5WPⓧ05-180	197	⊗	
16'		5WPⓧ05-192	208	⊗	

ⓧ = COLOR OPTIONS AVAILABLE | **B** = Black **G** = Green **N** = Bronze  
**S** = Sand **TB** = Tube Brown  
**W** = White

⊗ = NON-STOCKED PRODUCT  
 For details, see Ameristar's Sales Policy in the catalog guide.

Effective: 01/01/18

# WIREWORKS PLUS® | V-FOLD WELDED WIRE GATES

GATE HARDWARE SOLD SEPARATELY

	OPENING	ITEM NUMBER	WEIGHT	STOCKING
6' HEIGHT	3½'	5WP⊗06-42	73	⊗
	4'	5WP⊗06-48	79	⊗
	5'	5WP⊗06-60	90	⊗
	6'	5WP⊗06-72	102	⊗
	7'	5WP⊗06-84	130	⊗
	8'	5WP⊗06-96	141	⊗
	9'	5WP⊗06-108	152	⊗
	10'	5WP⊗06-120	164	⊗
	11'	5WP⊗06-132	175	⊗
	12'	5WP⊗06-144	186	⊗
	13'	5WP⊗06-156	197	⊗
	14'	5WP⊗06-168	209	⊗
15'	5WP⊗06-180	220	⊗	
16'	5WP⊗06-192	231	⊗	
8' HEIGHT	3½'	5WP⊗08-42	88	⊗
	4'	5WP⊗08-48	94	⊗
	5'	5WP⊗08-60	106	⊗
	6'	5WP⊗08-72	118	⊗
	7'	5WP⊗08-84	153	⊗
	8'	5WP⊗08-96	165	⊗
	9'	5WP⊗08-108	178	⊗
	10'	5WP⊗08-120	190	⊗
	11'	5WP⊗08-132	202	⊗
	12'	5WP⊗08-144	214	⊗
	13'	5WP⊗08-156	227	⊗
	14'	5WP⊗08-168	239	⊗
15'	5WP⊗08-180	251	⊗	
16'	5WP⊗08-192	263	⊗	

⊗ = COLOR OPTIONS AVAILABLE | **B** = Black **G** = Green **N** = Bronze  
**S** = Sand **TB** = Tube Brown  
**W** = White

⊙ = NON-STOCKED PRODUCT  
 For details, see Ameristar's Sales Policy in the catalog guide.

Effective: 01/01/18

TO PLACE YOUR ORDER CALL 888-333-3422 | VISIT AMERISTARFENCE.COM

**AMERISTAR**  
**ASSA ABLOY**

**Noble Creek fencing  
option - Y bracket**





**Noble Creek fencing  
option - Y bracket**



# ATTACHMENT B - Previous Project Staff Reports



**Beaumont-Cherry Valley Water District  
Regular Board Meeting  
March 26, 2020**

Item 7

STAFF REPORT

**Previously Provided**

**TO:** Board of Directors  
**FROM:** Dan Jagers, General Manager  
**SUBJECT:** **Authorize the General Manager to Award a Contract to Red Hawk Services, Inc. in an Amount Not to Exceed \$92,566.00 for the Noble Creek Recharge Facility Phase I Fencing Project**

---

### **Staff Recommendation**

Authorize the General Manager to enter into a contract with Red Hawk Services, Inc. for Bid Schedule 1A for an amount not to exceed \$92,566.00 (including contingency) to construct approximately 2,730 linear feet of six-foot high (6') galvanized chain link fencing (without 3 strand barbed wire top finish) at the Noble Creek Recharge Facility Phase 1;

Or

Consider alternative fencing option authorization.

### **Background**

The Beaumont-Cherry Valley Water District (BCVWD) Board of Directors and District staff have discussed various options to secure the Noble Creek Recharge Facility Phase 1 (NCRF PH I), located on the east side of Beaumont Avenue between Brookside Avenue and Cherry Valley Boulevard. The overall NCRF is approximately 82 acres, of which Phase I is approximately 28.5 acres with Phase 2 consisting of approximately 53.5 acres.

The Phase I facility was constructed in 2006 and intended to allow day use with a "community park" purpose. The facility is currently open to the public from sunrise to sunset with an open space parking area and trails between and along the sides of the recharge ponds, however, there is 24-hour access to the public via foot traffic. Additionally, NCRF PH I has a white split-rail vinyl fence around the perimeter of the percolation ponds and the property.

Noble Creek bisects the Phase I and Phase 2 facilities with Phase 2 being on the east side of the creek and constructed in 2014. The Phase 2 facility has a 6' galvanized chain link fence around its perimeter and does not allow access to the public. See Figure 1 for the Project Site Map.

District staff prepared and issued contract documents for proposed fencing options to be constructed along the perimeter of NCRF PH I for the frontage on Beaumont Avenue and Cherry Valley Boulevard on February 13, 2020. The fencing Bid Schedule options identified three (3) different fence options; galvanized, extruded bonded, and fused bonded (1, 2, and 3 respectively). For each fence type, the contract bid documents also detailed a 6' and 8' high option for each fence type (1A, 1B, 2A, 2B, 3A, and 3B respectively). A non-mandatory pre-bid meeting was held on February 25, 2020 with an addendum to the contract documents issued on March 5, 2020. Bids were due to be submitted on March 11, 2020 and the District received two (2) bids. The bids





received were from Red Hawk Services, Inc. and Fence Corp, Inc. Each company is relatively local with Red Hawk Services, Inc. located in Perris and Fence Corp, Inc. located in Riverside.

**Summary**

Tables 1, 2, and 3 set forth bids received for each Bid Schedule separated by fence material option and height:

**Table 1**

<b>Noble Creek Recharge Facility Phase I Fencing</b>					
<i>Bid Schedule 1 - Galvanized Chain Link Fence</i>					
<b>Bidder</b>	<b>Base Bid Schedule 1A (6 FT)</b>	<b>Base Bid Schedule 1B (8 FT)</b>	<b>Additive Bid (3-Strand Barbed Wire)</b>	<b>Total Bid Schedule 1A</b>	<b>Total Bid Schedule 1B</b>
Red Hawk Services, Inc.	\$76,919.15	\$95,678.94	\$7,231.58	<b>\$84,150.73</b>	<b>\$102,910.52</b>
Fence Corp, Inc.	\$89,555.60	\$98,621.76	\$6,642.16	\$96,197.76	\$105,263.92

**Table 2**

<b>Noble Creek Recharge Facility Phase I Fencing</b>					
<i>Bid Schedule 2 - Extruded Bonded Chain Link Fence</i>					
<b>Bidder</b>	<b>Base Bid Schedule 2A (6 FT)</b>	<b>Base Bid Schedule 2B (8 FT)</b>	<b>Additive Bid (3-Strand Barbed Wire)</b>	<b>Total Bid Schedule 2A</b>	<b>Total Bid Schedule 2B</b>
Red Hawk Services, Inc.	\$88,593.24	\$121,269.17	\$10,943.00	<b>\$99,536.24</b>	<b>\$132,212.17</b>
Fence Corp, Inc.	\$98,621.76	\$122,862.56	\$6,642.16	\$105,263.92	\$129,504.72

**Table 3**

<b>Noble Creek Recharge Facility Phase I Fencing</b>					
<i>Bid Schedule 3 - Extruded Bonded Chain Link Fence</i>					
<b>Bidder</b>	<b>Base Bid Schedule 3A (6 FT)</b>	<b>Base Bid Schedule 3B (8 FT)</b>	<b>Additive Bid (3-Strand Barbed Wire)</b>	<b>Total Bid Schedule 3A</b>	<b>Total Bid Schedule 3B</b>
Red Hawk Services, Inc.	\$102,043.67	\$129,605.13	\$10,943.00	\$112,986.67	\$140,548.13
Fence Corp, Inc.	\$92,214.12	\$113,499.44	\$6,642.16	<b>\$98,856.28</b>	<b>\$120,141.60</b>

District staff further identifies that the galvanized fencing material used to enclose nearby surrounding establishments (including the recently completed San Geronimo Pass Water Agency Recharge Facility), District staff is recommending the Board of Directors consider approving the 6' galvanized chain link fencing option for the NCRF PH I facility. Table 4 below sets forth associated costs to enter into contract with Red Hawk Services, Inc. to proceed with fencing installation per Base Bid Schedule 1A. Said work includes a 10% contingency.





**Table 4**

<b>Item</b>	<b>Description</b>	<b>Base Amount (Basis of Award)</b>
1	Base Bid Work (Installation of 6' High Chain Link Fencing, Access Gates, and Appurtenances (with barbed wire)	\$84,150.73
	Contingency (10%)	\$8,415.07
<b>Total Requested Contract Amount</b>		<b>\$92,566.00</b>

It should be further noted that barbed wire top finish is part of the Staff recommended fencing option.

**Fiscal Impact**

The fiscal impact to the District for this project will be an amount not to exceed \$92,566.00, as set forth in Tables 4. This not-to-exceed amount includes additional funds to provide approximately 10% contingencies for construction related costs.

While the Noble Creek Recharge Facility – Phase I Fencing Project is not part of the District’s 2020 Operating/Capital Budget, funds are available from the Capital Replacement Reserve budget for completion of this work.

**Attachment(s)**

- Attachment 1 – Project Location Map
- Attachment 2 – District Approved Project Plans



# Attachment 1 Project Location Map



*Not to Scale*



**Attachment 2**  
**District Approved Project Plans**

# BEAUMONT-CHERRY VALLEY WATER DISTRICT FENCING PLAN FOR NOBLE CREEK RECHARGE FACILITY PHASE I

LOCATED WITHIN A PORTION OF SECTION 27, TOWNSHIP 2 SOUTH, RANGE 1 WEST, S.B.M.

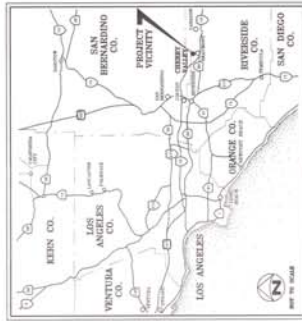
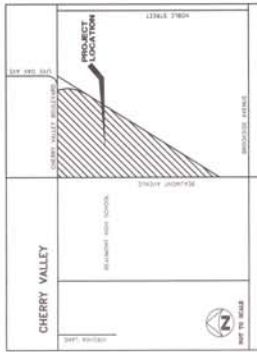

SHEET No.	DESCRIPTION
1	TITLE, VICINITY MAP, SHEET INDEX, LEGEND, CONSTRUCTION NOTES
2	AREA 1 FENCING PLAN
3	AREA 2 FENCING PLAN

## SHEET INDEX

UNITS	QTY
LF	2,732±
EA	3
EA	4
EA	1
LF	2863±

### LEGEND

- EXIST. CHAINLINK FENCE
- PROPOSED CHAINLINK FENCE
- PROPOSED DOUBLE SWING GATE
- PROPOSED 4" MANGATE



SCALE: 1"=100'

**FOR BIDDING PURPOSES ONLY**

	<b>BEAUMONT-CHERRY VALLEY WATER DISTRICT</b> <small>500 Magnolia Ave. • Beaumont, CA 92223 • 951-848-1081</small>	<b>BCVWD</b> NOBLE CREEK RECHARGE FACILITY PHASE I FENCING PLAN	<b>SHEET</b> <span style="font-size: 2em;">1</span> OF 3 SHEETS	TITLE, VICINITY MAP, SHEET INDEX, LEGEND, CONSTRUCTION NOTES
APPROVED BY: <i>[Signature]</i> REGISTERED ENGINEER No. <b>71233Z</b>	DATE: <b>02-13-2020</b>	AS NOTED FIELD BOOK: <i>[Initials]</i> DESIGN: <i>[Initials]</i> DRAWN: <i>[Initials]</i> CHECKED: <i>[Initials]</i>		
BEAUMONT-CHERRY VALLEY WATER DISTRICT 48 hour-BEFORE-recording 1-(800)227-2600 DUL (Intergraph) Service Ref.	REVISIONS DATE BY			FILE NO.



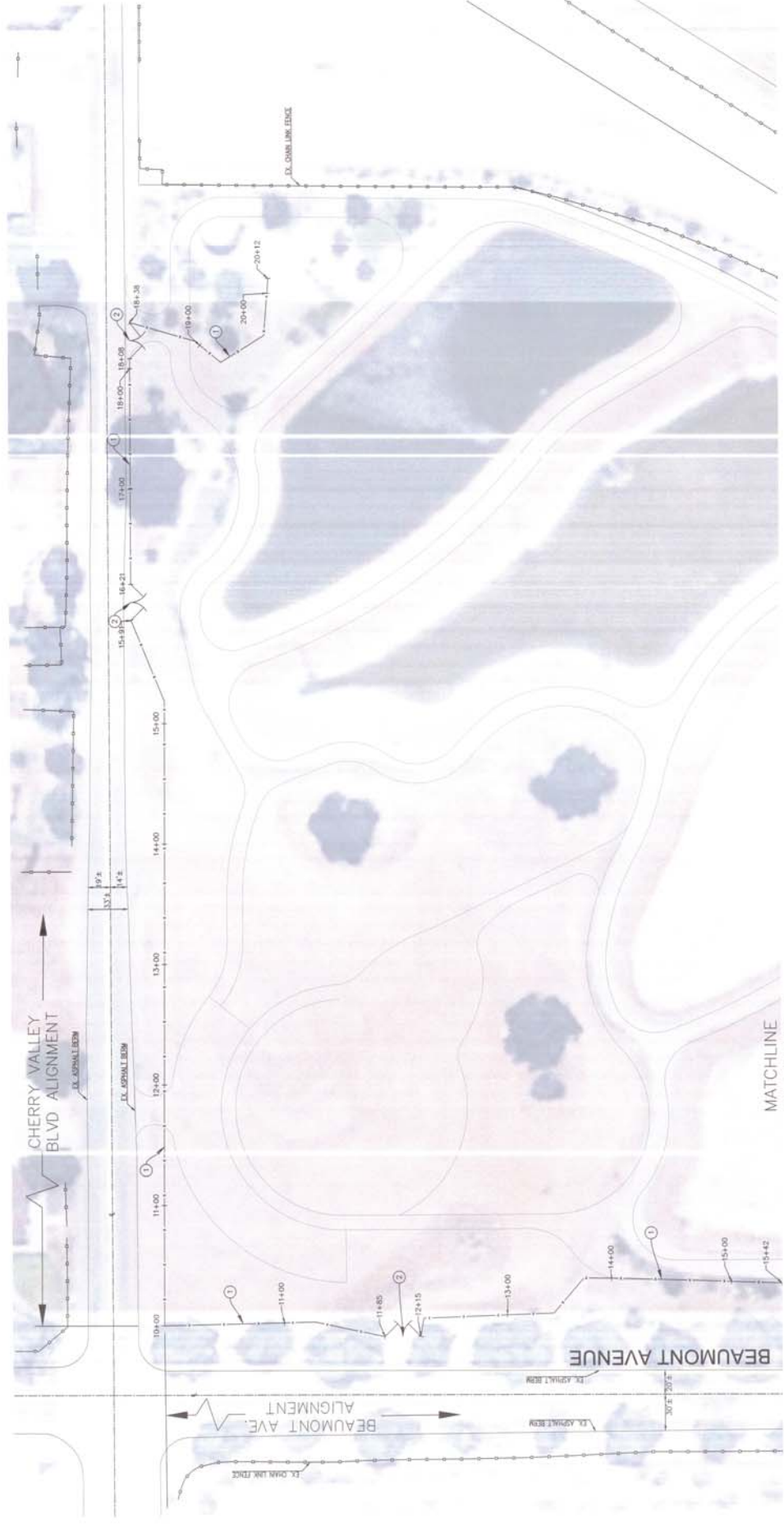

NOTES:  
 1. DIMENSIONS SHOWN ON PLANS ARE APPROXIMATE. CONTRACTOR SHALL FIELD VERIFY AND QUOTE FENCING MATERIALS BASED UPON ACTUAL FIELD MEASUREMENTS.

- CONSTRUCTION NOTES**
- ① INSTALL 6" HIGH CHAINLINK FENCE PER BID SCHEDULE
  - ② INSTALL 30" WIDE CHAINLINK DOUBLE SWING GATE PER BID SCHEDULE "XX" (OPTIONAL)
  - ③ 30" WIDE AUTOMATIC ROLLING GATE PER ADDITIVE BID ITEM "XX"

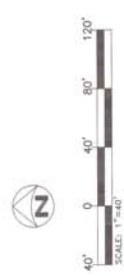

**FOR BIDDING PURPOSES ONLY**

SCALE AS NOTED  
 FIELD BOOK 11/4  
 DESIGN DAB  
 DRAWN DAB  
 CHECKED WSS/DWJ

SHEET **2**  
 OF 3 SHEETS  
 FILE NO.

**BEAUMONT-CHERRY VALLEY WATER DISTRICT**  
 5450 Magnolia Ave. • Beaumont, CA 92223 • 951-845-9981

APPROVED BY: [Signature]  
 REGISTERED ENGINEER NO. 72392 DATE 05-18-2024



NO.	DATE	BY	REVISIONS

BEAUMONT-CHERRY VALLEY WATER DISTRICT

48 Hours BEFORE OCCUPATION  
 1-(800)227-2600  
 CALL Underground Service Alert

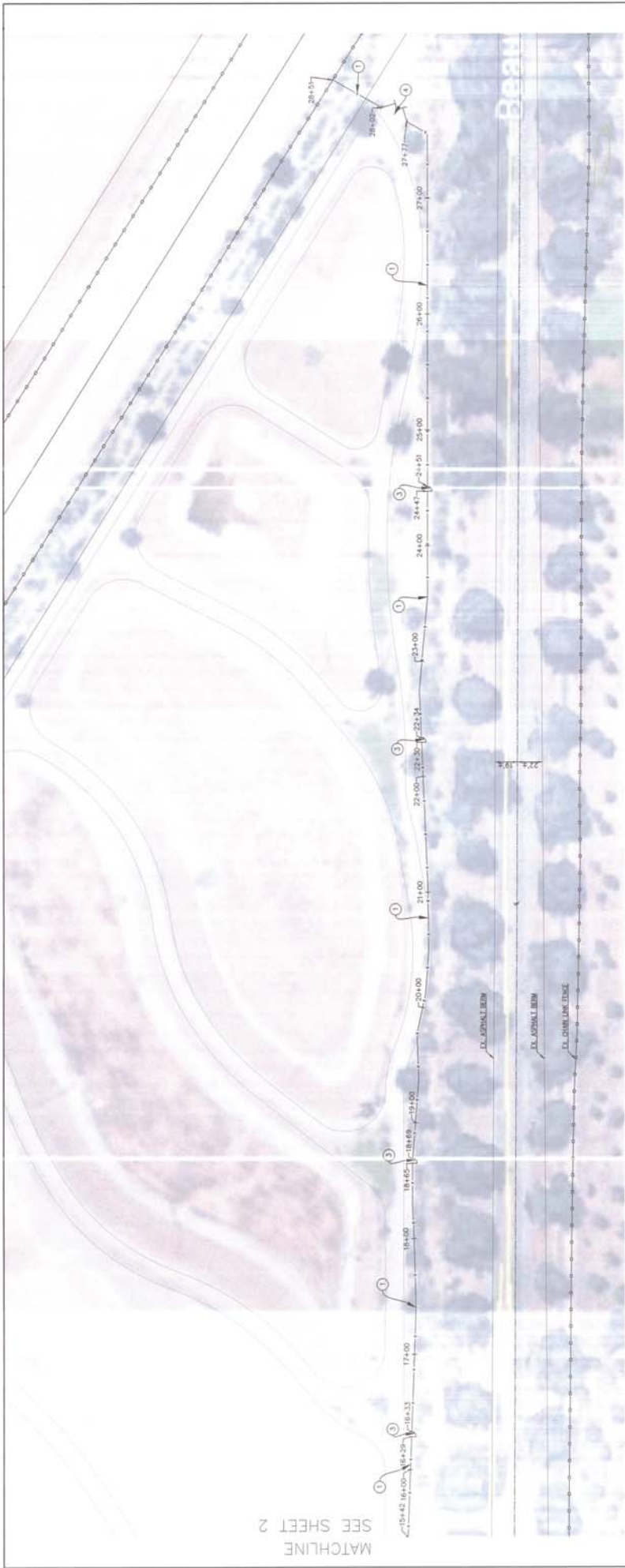

MATCHLINE  
SEE SHEET 2



**CONSTRUCTION NOTES**

- 1. INSTALL 6' HIGH CHAIN LINK FENCE PER BID SCHEDULE
- 2. INSTALL 4' WIDE CHAIN LINK GATE PER BID SCHEDULE "XX"
- 3. INSTALL 25' WIDE CHAIN LINK DOUBLE SWING GATE PER BID SCHEDULE "XX" (OPTIONAL 25' WIDE AUTOMATIC ROLLING GATE PER ADDITIVE BID ITEM "XX")

NOTES:  
1. DIMENSIONS SHOWN ON PLANS ARE APPROXIMATE.  
CONTRACTOR SHALL FIELD VERIFY AND QUOTE FENCING MATERIALS BASED UPON ACTUAL FIELD MEASUREMENTS.

**FOR BIDDING PURPOSES ONLY**

BCVWD  
NOBLE CREEK RECHARGE FACILITY  
PHASE 1 FENCING PLAN  
AREA 2 FENCING PLAN

3  
OF 3 SHEETS  
FILE NO.

BEAUMONT-CHERRY VALLEY WATER DISTRICT  
550 Argonne Ave., Beaumont, CA 92223 • (951) 843-9981

APPROVED BY: \_\_\_\_\_ DATE: 02-13-2020  
REGISTERED ENGINEER No. 72332

SCALE AS NOTED  
FIELD BOOK 1974  
DESIGN DAB  
DRAWN DAB  
CHECKED WST/DUJ



SYN	REVISIONS	DATE	BY

48 hours BEFORE RECEPTION  
1-(800)227-2600  
DLI Underground Service Alert